

**Interconnection Requirements for
Small Net Metering Distributed Generators
(Solar PV, \leq 25 kW)**

**Addendum
to
Net Metering Interconnection Requirements,
50 kW & Below
Rate Schedule RS 1289
(issued 22 October 2003)**

May 03, 2011

BC hydro 

Scope

This addendum supplements and amends the requirements of the base document, “Net Metering Interconnection Requirements, 50 kW & Below” (NMIR/50) available at http://www.bchydro.com/planning_regulatory/acquiring_power/net_metering.html .

The addendum specifies the requirements for interconnection of Small Net Metering Distributed Generators (NM DGs) only. Technical requirements for all other NM DGs are identified in the main document, NMIR/50.

The intent of this document is to assist customers (“the DG owner”) in preparing an application for a Small NM DG interconnection with BC Hydro. The document is also intended to identify and clarify the simplified technical requirements related to Small NM DGs which are typically small residential solar, inverter-based, installations.

For the purposes of this document, a Small NM DG system shall meet all of the following:

- Interconnected to the utility distribution system by an inverter(s) certified to
 - CSA C22.2 No.107.1 with total rated capacity ≤ 25 kW or
 - UL 1741 with total rated capacity ≤ 10 kW
- Total aggregate capacity, at Point of Common Coupling (PCC), to be ≤ 25 kW
- Energy source must be solar photovoltaic (PV)
- Inverter output is 120 V or 240 V 1-phase
- BC Hydro service is 120/240V, 1-phase, single meter, maximum size 200 A

General Requirements

Small NM DGs shall be installed in accordance with the Canadian Electrical Code (CEC), Part I, CAN/CSA-C22.2 No. 0, and CSA C22.2 No 257-06. All equipment shall meet the requirements of the applicable Standards of the CEC, Part II. Specifically, the DG owner should refer to Section 84 of the CEC and to CSA C22.2 No. 257-06 “Interconnecting Inverter-Based Micro-Distributed Resources to Distribution Systems”.

Small NM DG installations meeting the above requirements are subject to inspection and permitting as required by the applicable local inspection authority and shall meet all applicable national, provincial, and local, design, construction, and safety codes and regulations.

Interconnection and Protection Requirements

Point of Common Coupling (PCC)

The PCC is the point where the BC Hydro system and the DG owner’s installation interconnect. This is typically at the weatherhead (for overhead service connections) or at the revenue meter base (for underground service connections). BC Hydro is responsible for design, construction, maintenance, and operation of all facilities on the BC Hydro side of the PCC. The DG owner shall be responsible for design, construction, inspection, maintenance, and operation of all facilities on their side of the PCC.

Point of Disconnection (DG System Disconnect Means)

For Small NM DGs, BC Hydro does not require access to the customer's means of disconnection (DG System Disconnect Means as described in the NMIR/50, clause 3.2.2 and in the Appendix A). The DG owner should refer to the Canadian Electrical Code, Section 84, for code requirements. BC Hydro relies on compliance with the provisions of the Code to ensure public and worker safety.

Anti-islanding

The safety of electrical workers and the public is ensured by the use of CSA or UL certified inverters which will not back-feed into BC Hydro system when the incoming BC Hydro service is not energized. The anti-islanding requirements of CSA C22.2 No. 257, CSA C22.2 No. 107.1, and/or UL 1741 require the inverter to cease energizing the distribution system upon loss of the BC Hydro supply.

Inspection, Testing, and Commissioning

General

If requested, the DG owner will provide to BC Hydro a list of step-by-step energizing and commissioning procedures prior to DG system commissioning and shall make available, upon request, a complete set of manuals and installation drawings.

Anti-islanding Function Testing

If there is no manufacturer's recommendation, the inverter anti-islanding function shall be checked by opening a disconnecting means (DG System disconnect, a branch breaker, or other appropriate) to simulate loss of utility power and to verify that the inverter output will cease to energize within 2 seconds.

Upon closing of the disconnecting means, the inverter energizing is to be time delayed as required by the manufacturer (typically ≥ 5 min).

Commissioning and Verification Testing

Prior to completion of commissioning of the DG system, or when the inverter is modified, a verification test shall be performed as recommended by the equipment manufacturer. The DG owner is also responsible for ensuring that all requirements of the local inspection authority related to inspection and/or testing are adhered to in order to ensure the safe interconnection of the equipment with the BC Hydro system. The DG owner must notify BC Hydro of any subsequent changes to equipment to confirm that the proposed replacement equipment still qualifies as a Small Net Metering Distributed Generator installation.

BC Hydro reserves the right to witness field verification testing or to require written certification that the testing was completed. All verification tests prescribed by the manufacturer or developed by the DG owner (and agreed to by BC Hydro) shall be performed prior to interconnection. The DG owner shall retain verification test reports and make them available to BC Hydro if requested.

Maintenance & Operation

In addition to keeping all equipment well maintained and functional, the DG owner shall verify the inverter’s anti-islanding function operation according to the manufacturer’s recommended schedule, or in its absence, at least once a year. Notwithstanding the above, BC Hydro strongly recommends that the DG Owner verifies the inverter’s anti-islanding functionality more frequently (i.e. monthly). The DG owner shall maintain the verification test records for a period of two years and, if requested, submit the test records to BC Hydro.

An acceptable method for verification of the inverter anti-islanding functionality is described in the Anti-islanding Function Testing section above.

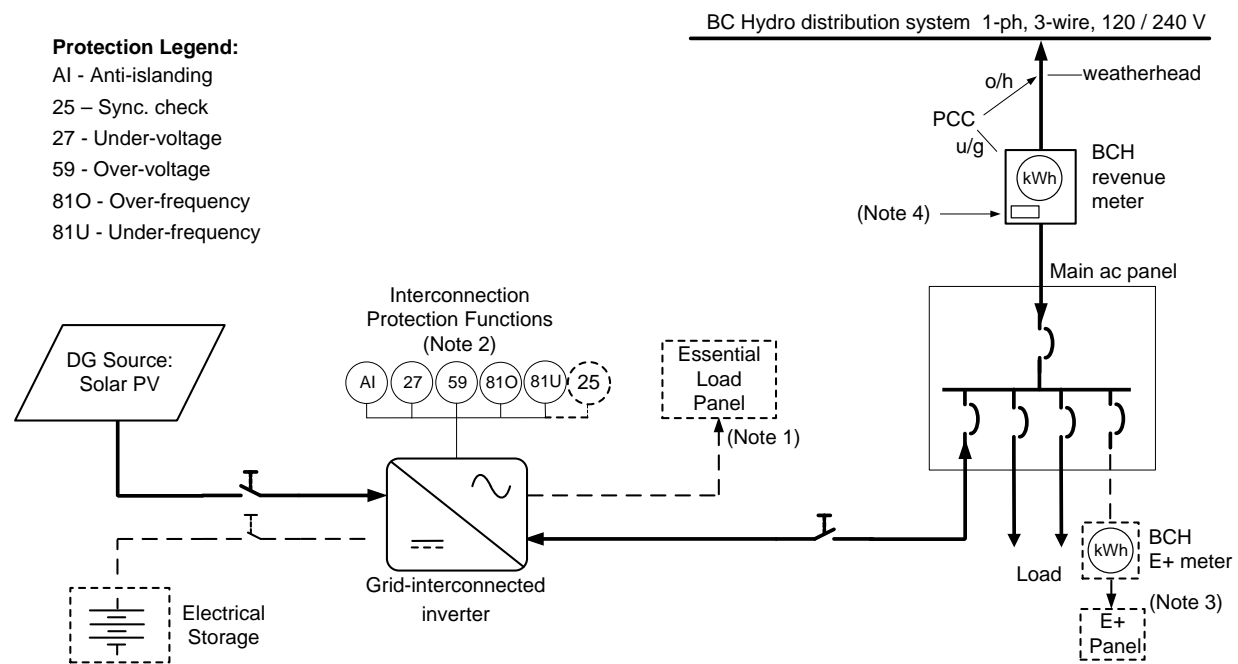

NOTES:

1. Elements shown with dashed line (— — —) are not typical for every installation.
2. Protection functions shown shall be internal for the inverter. In addition, Simple NM DG shall have instantaneous (50) and timed overcurrent functions (51). Reference NMIR/50, Table 5. The 50 and 51 functions may be part of inverter, too.
3. Some BC Hydro customers have a separately metered sub panel for electric heating (i.e. E-Plus panel –rate schedule RS1105). No NM DG shall be connected to an E-plus panel.
4. This is a warning notice required by Clause 84-030 of the Canadian Electrical Code (2009). BC Hydro requires that the notice should be a permanent label suitable for outdoor conditions, with black letters on a white background, of a size and wording as indicated in the Figure 2 below. The notice must be mounted on the meter base (box), or if there is no meter base on the wall within 0.3 m (1 ft) of the meter.

Figure 1: Single Line Diagram, Typical Installation of Small Net Metering Distributed Generator (NM DG)

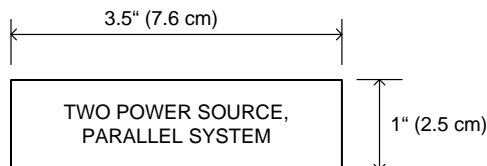

Figure 2: Warning Notice at BCH Revenue Meter