

**02SH36**  
**THE PROCTER CHANNEL**  
**FINAL REPORT**



Submitted by: Gay Jewitt, Administrator  
Whitevalley Community Resource Centre  
Prepared by: Thomas Minor, BSc, CET  
Date: April 12, 2003

## **Acknowledgements**

**This project was made possible through the cooperation and joint efforts of:**

**Robin Hahn and Kelly Law, Landowners**

**Rudy and Melanie Affolter, Landowners**

**Bruce Unwin, Landowner**

**Art Chambers, Landowner**

**The Procter Family, Landowners**

**James and Charlene Huwer, Landowners**

**Fisheries and Oceans Canada, Kamloops**

**Funding for this project was provided by:**

**BC Hydro Fish and Wildlife**

**Bridge Coastal Restoration Program**

# Table of Contents

	Page
ACKNOWLEDGEMENTS .....	ii
LIST OF FIGURES .....	v
LIST OF TABLES .....	vi
EXECUTIVE SUMMARY .....	vii
1.0 INTRODUCTION .....	1
2.0 SITE DESCRIPTION.....	3
3.0 METHODS .....	6
3.1 CONSTRUCTION .....	6
3.1.1 SETTLING POND .....	6
3.1.2 PIPELINE AND INFILTRATION GALLERY.....	8
3.1.3 WATER JUMP .....	12
3.1.4 CONTROL VALVE .....	13
3.1.5 INTAKE .....	14
3.1.6 ROAD PRISM .....	18
3.1.7 CROSSINGS .....	19
3.1.8 REFUGE HOLES AND SPAWNING RUNS .....	22
3.2 PLANTING .....	23
3.3 FENCING .....	26
4.0 RESULTS .....	30
5.0 RECOMENDATONS .....	36
6.0 REFERENCES .....	38

APPENDIX A: MAPS, DRAWINGS .....	39
APPENDIX B: BEFORE AND AFTER PHOTOS .....	44
APPENDIX C: FINANCIAL STATEMENT .....	75
APPENDIX D: NEWSPAPER ARTICLES AND SIGNAGE .....	77

**LIST OF FIGURES**

FIGURE 1: ARIEL OVERVIEW ..... 2

FIGURE 2a: WOOD IN CHANNEL BEFORE WATER ..... 4

FIGURE 2b: WOOD IN CHANNEL AFTER WATER ..... 5

FIGURE 3: SEDIMENT POND EXCAVATION ..... 7

FIGURE 4: SOD REPLACEMENT ..... 8

FIGURE 5: INFILTRATION GALLERY SECTION ..... 10

FIGURE 6: INFILTRATION GALLERY PLACEMENT ..... 10

FIGURE 7: PUMP ..... 11

FIGURE 8: WATER JUMP ..... 12

FIGURE 9: MANHOLE HOUSING FOR CONTROL VALVE ..... 13

FIGURE 10: CONTROL VALVE BEING FITTED OVER PIPE ..... 14

FIGURE 11: INTAKE STRUCTURE DRAWING ..... 15

FIGURE 12: INTAKE STRRUCTURE WITH INNER GRILL ..... 15

FIGURE 13: INTAKE STRUCTURE WITH PIPE ATTACHED ..... 16

FIGURE 14: ELEVATION CHECK ON INTAKE SITE ..... 17

FIGURE 15: BACKFILLING ROAD PRISM ..... 18

FIGURE 16: RIPRAP..... 19

FIGURE 17: CULVERTS ..... 20

FIGURE 18: CROSSING ..... 22

FIGURE 19: WILLOW STAKES ..... 25

FIGURE 20: RAIL FENCE..... 27

FIGURE 21: WILDLIFE PASSAGE ..... 28

FIGURE 22: HESKETH BRACE .....	28
FIGURE 23: BRACE WITH GATE .....	29
FIGURE 24: GROUNDWATER FLOW .....	32
FIGURE 25: POND EROSION .....	33
FIGURE 26a: TRAMPLED CREEK WITHOUT FENCE .....	34
FIGURE 26B: CREEK RE-DEFINED AND FENCED .....	34

## **LIST OF TABLES**

TABLE 1: LIST OF LANDOWNERS .....	3
TABLE 2: LIST OF CULVERT SIZES .....	20
TABLE 3: PLANT SPECIES .....	23
TABLE 4: FENCE TYPES .....	26
TABLE 5: IN-KIND CONTRIBUTIONS .....	36

## **Executive Summary**

This project was highly successful. It was completed on time, on budget and the results have exceeded the expectations.

Work was slow to begin due to the number of landowners involved and the difficulty of in scheduling meetings. Two of the landowners are non-residents; one living in Germany, so correspondence was time consuming.

Once work got underway in December, construction time was reduced due to the unseasonably warm dry weather and the low water table.

Whitevalley Community Resource Centre (WCRC) involved the landowners in both the planning and construction of the project as much as possible. This not only increased landowner understanding and appreciation of the project, but help to cut project cost as well.

The intake was opened in February. With some minor adjustments, water levels were where they were expected to be. Fry were observed in the top and bottom ends of the channel in mid May. By June, they were seen within a kilometer of either end.

The water in the channel remained clear even when the river began to rise and become turbid. With the intake valve shut, the channel still receives about 2 ft<sup>3</sup>/s of groundwater from the infiltration gallery. The volume of water increases with the length of the channel from additional groundwater.

## 1.0 INTRODUCTION

Coho salmon have declined in numbers in the Middle Shuswap over time and hit the lowest point in the period of record (50 years) in 2001 (Arc Environmental 2001). The Shuswap hatchery switched from raising Chinook to Coho in 1998 with egg targets set at 100,000. They have not been able to reach this goal due to lack of brood stock. One of the reasons for the decline in the Coho stock is believed to be the lack of rearing habitat. Fisheries and Oceans Canada (DFO) and Whitevalley Community Resource Centre (WCRC) have been working to ameliorate this shortage by constructing or enhancing rearing channels in both the Middle Shuswap and the Bessette systems.

Patrick Cochran, engineering technician for the Habitat Section of the Kamloops DFO, suggested the Procter Channel as a potential salmon rearing project to WCRC in 2001. He had done the initial survey several years earlier and thought it possible to create several kilometers of rearing habitat cost effectively. There was a remnant channel that flowed during freshet but became a fish trap when the water levels dropped and the channel became isolated from the river. The greatest challenge to getting the project going was getting the co-operation of the seven landowners who would be involved.

DFO had some difficulties with landowner relations in the Mabel Lake valley that discouraged them from approaching the landowners themselves. Because of WCRC's recent successes in arbitrating some of these differences, DFO suggested that WCRC try. DFO would offer technical support, but otherwise stay in the background.

Lee Hesketh, stewardship coordinator for the Cattleman's Association and long-time resident of the Mabel Lake area made the initial contacts with the landowners. Most were in favor of a project that improved the salmon stocks, but also had strong reservations about allowing any government agency to have more influence over their properties and farming practices than they already had. Lee was able to overcome their reluctance by calling a meeting of all the landowners and inviting Joe and Pete Huwer. The Huwers had

once refused a project proposal by DFO on their properties but later had agreed to let the project go ahead under WCRC supervision. They were pleased with the results of the project on their property and had greatly improved their understanding and relations with DFO. They were willing to voice their support for future projects taken on by WCRC. As a result of that meeting, the landowners signed a letter of support for the channel through their properties.

At a later meeting the landowners were asked if they had any preferences to what the channel would be called. DFO and WCRC had originally referred to it as the Bigg Channel because the early plans considered using water from Bigg Creek to supply the channel rather than diverting water from the Shuswap River. (There was inadequate summertime flow.) The landowners voted to name it the Procter Channel after the family that homesteaded the Mabel Lake valley.



Figure 1: The photo shows an overview of the Procter channel looking north. From the intake on the Shuswap River (bottom right) there is 300 m of buried pipe diverting water to the sediment pond. From the sediment pond, the water flows into existing channels and wetlands. Photo taken Feb 2003.

## 2.0 SITE DESCRIPTION

The intake for the Procter Channel site is located on the Middle Shuswap River approximately 8.5 km downstream of the Wilsey Dam (BCGS map 82L037). This is immediately downstream of the most heavily utilized spawning area in the Middle Shuswap (Arc Environmental 2001). It is about 5 km downstream of the Bessette Creek confluence, the largest tributary to Middle Shuswap. The Procter Channel consists of remnant channels that have been cut off from the Shuswap River at the upstream end. It flowed intermittently from groundwater contributions and surfacial runoff from the adjacent hillsides. The remnant channels contain approximately 13 hectares of ponds and cattail marches (Figure 1).

The Procter Channel flows through the property of seven landowners (Table 1). Two of the landowners are non-resident. One property is owned by the Affolters in Enderby and one property is owned by a limited company. Gerry Laarakker, a lawyer in Winfield, is the contact for the owners of the company.

Table 1: The landowners involved in the Procter Channel and their properties.

Landowner	PID #	Land Description	Legal Description
Robin Hahn Christine Law	003-917-495	Agricultural	Lot A, Plan B1469, Sec 6, Township 43, except Pl 2178, 24527 Osoyoos Div of Yale District
Melanie Affolter Rudy Affolter	003-287-238	Agricultural	Lot 1, Pl 569, Sec 5-6, Township 43, except Pl 13690, Osoyoos Div of Yale District
Bruce Unwin	003-717-011	Agricultural	Lot A, Pl 31425, Sec 5-6, Township 43, Pl 38202, Osoyoos Div of Yale District
Arthur Chambers	003-815-226	Agricultural	Lot 1, Pl 31087, Sec 5-6, except Pl 31425, Township 43, Osoyoos Div of Yale District
459218BC Ltd	016-289-536	Agricultural	Part SE1/4, Sec 7, Township 43
	016-289-544	Agricultural	Part SW1/4, Sec 7, Township 43
	013-622-897	Agricultural	Part SW1/4, Sec 8, Town 43, except Pl 11131, 16350, 17142, 19953 Osoyoos Div of Yale District

Leroy Proctor	013-621-114	Agricultural	Part E1/2 of NE1/4, Sec 7, Township 43 Osoyoos Div of Yale District
Jim Huwer	023-096-942	Agricultural	Lot 2, Pl KAP54917, Sec 17-18, Township 43 Osoyoos Div of Yale District

The land adjacent to these channels is largely agricultural, being used for pasture and hay production. The existing riparian width along the old channel varies from 20 m to over 120 m. The riparian is largely deciduous, the merchantable timber having been removed. The old channels are richly complexed with woody debris due to the old clearing practices. When the adjacent fields were being cleared, the stumps and unusable logs were pushed into the old channels both to dispose of the waste and create fill to enlarge the fields. Much of the cedar roots and logs still are present and provide in-stream cover (Figures 2a & b).



Figures 2a: Trees and roots were often pushed into sloughs when the land was cleared. Photo taken in November 2002



Figure 2b: The wood debris left from land clearing becomes fish habitat when water is added to the remnant channel. Photo taken in May 2003.

The intake structure is located 70 m downstream of the Bailey bridge on the right (north) bank of the river on Lawrence Road (off of Mabel Lake Road). The bank is a heavily riprapped downstream of the bridge for over 100 m. Bigg Creek enters the Shuswap 20 m upstream of the bridge.

The intake structure is made of concrete, 1.3 m high, 3.1 m wide and 1.5 m deep. There is a fixed metal grill set in the back wall of the structure covering the pipe hole and another removable grill that goes from the bottom front to the top of the back of the structure. There is a 600 mm smooth double-walled plastic pipe leading from the intake structure to the control valve located on the north side of Lawrence Road. The pipe invert at the river has an elevation of 401.7 m. The water surface of the river was 402.5 m when the pipe was laid in January 2003.

The control valve is located in a manhole made of 1.2 m concrete rings. It consists of a metal plate that slides over the front of the pipe leading to the sediment pond. The plate is

held in place by grooves that slide over the end rib of the pipe (Figure 10). The valve is controlled from the top of the manhole by a pulley that lifts or lowers the plate. It is not necessary to climb into the manhole for setting the valve. The manhole is access by a padlocked metal door.

The 600 mm pipe continues for 300 m from the valve across the property of Robin Hahn to the excavated sediment pond with a slope of 0.1%. The pond is roughly kidney shaped about 50m long and 15 m wide. It is about 2 m deep with gently sloping sides. The pipe invert at the pond is 401.4 m and the water surface averages about 402.1 m. The outlet to the pond is 20 m from the Hahn/Affolter property line. A 12 m pipe arch culvert was buried at the property line providing access across the channel on both the Hahn and Affolter properties. The culver empties into the remnant channel. The culvert invert is 401.8 m. There was no need for excavating the channel below the Hahn property other than to make refuge holes.

The channel meanders for approximately 4 kms through the properties of Melanie and Rudy Affolter, Bruce Unwin, Art Chambers, leasee Wayne Hughs (the property is under foreign ownership – 459218BC Limited), Leroy Proctor and Jim Huwer before re-entering the Shuswap. It has a wetted area of approximately 13 ha.

## **3.0 METHODS**

### **3.1 CONSTRUCTION**

#### **3.1.1 SETTLING POND**

Excavation began December 2 on the Hahn property. Two excavators, a John Deere 790 @ \$105/hr and a John Deere 690 @ \$100/hr were hired to dig the sediment pond and to dispose of the waste material. The sediment pond is located on the Hahn property 300 m north of the Shuswap River. It is kidney shaped approximately 50 m long and 15 m wide

(Figure 3). Because of the fine material at the ground water level, the depth of the pond was limited to about 2 m at the widest sections. Trying to dig deeper just resulted in the sides sloughing in and the pond widening. The intake is at the south end and the outlet on the north end. Spawning gravel has been placed at the inlet, the narrow center and the outlet.



Figure 3: The settling pond located on the Hahn Property. Waste material was used to fill low spots on the adjacent fields while gravel was used for spawning areas.

The sod that was removed from the pond area was piled to the side and replaced along the sloped banks above the water line (Figure 4). The majority of the material excavated from the pond area was silt or clay and was taken to a low spot in the Hahn's field approximately 200 m away. Two dump trucks @ \$60/hr each, were hired to move the waste material from the pond area to the waste site. One excavator was used to excavate the pond and load the trucks while the second was used to lift the sod from the waste site, spread the waste material and scatter the sod on top. Some gravel material suitable for spawning gravel was found at the north end of the pond. This was put to the side and later spread at the center and outlet of the pond. The pond took two days to rough out.



Figure 4: The sod was replaced along the sloped edges of the settling pond. Shrubs and trees were planted in the spring.

### 3.1.2 Pipeline and Infiltration Gallery

The original plans called for 100 m of buried pipe and 200 m of open channel between the river and the settling pond. However, after several site visits, the DFO engineer decided that it would be safer to have a buried pipe the entire 300 m. If the river overtopped Lawrence road, the floodwaters could pick up energy in an open channel, cause erosion downstream and possibly erode back to the river. This change in plans resulted in higher labor cost, supervision time and cost of material but saved on planting, complexing and trucking.

The excavators began placing the 600 mm double-walled plastic pipe on Dec 4<sup>th</sup>. One excavator went ahead removing the dry material and piling it to one side. The second excavator followed and removed the material below the water table. Keeping the dry material separate from the wet material reduces the handling time, cuts down on the cleanup and minimizes the sediment that is generated. The water table was at a depth of about 1.2 m. The subsoil was silty clay turning to sand at 1 m depth. This layer of wet

sand caused the sides of the ditch to slough when dug below the water table. As a consequence the ditch had to be dug wider than planned. To dig a ditch 1m deep, the top of the ditch had to be 7- 10 m wide.

The sloughing action was minimized by removing the sandy material below the water table last with a slow even motion of the bucket. The bucket had to be lifted from the water that fills in behind it slowly to minimize the pore pressure differential between the water in the soil and that of the ditch when the lifting bucket creates a vacuum. The relatively higher pore pressure in the soil causes the sides of the ditch to cave in. This also minimized sediment reaching the pond.

The double walled pipe is buoyant and had to be weighted with sandbags to prevent it from floating. Two sand bags were tied together with rope and slung over the pipe. Three sets of bags were used to hold down each 9 m section of pipe while it was positioned, coupled and checked for grade. The pipe was placed at a 0.1% grade using a laser level. The pipe invert is 401.7 m at the river and 401.4 m at the pond.

An infiltration gallery (Figure 5) was placed along side the 600 mm pipe to collect groundwater. The gallery was placed where the material below the water table consisted of coarse sand and/or gravel to collect ground water (Figure 6).

The gallery is made up of 2 m sections of arch-shaped plastic that is open on the bottom and solid on the top. The sides have louvered slots that slant downwards. This allows water to flow in without sand falling in. The cross sectional area of the gallery is about 320 cm<sup>2</sup>. In areas where the material below the water table contained fines, a solid 25 cm diameter plastic sewer pipe was used to connect the infiltration galleries.

With a meter of head for the length of the gallery, the gallery picks up approximately 2 ft<sup>3</sup>/s when the intake valve is closed. There is less flow when the valve is open because there is less head due to the higher pond level, but the exact amount is not easy to measure.



Figure 5: Larry McGregor holds up a section of the intake gallery. The sides have slots that angle downwards. Water is able to flow in, but sand and gravel is kept out. This type of gallery has a larger exchange area than standard perforated pipe.



Figure 6: An infiltration gallery was placed beside the 600 mm pipe to collect groundwater. This will allow a flow of water even when the intake is closed. Sandbags were used to counter the buoyancy of the pipe.

The excavators laid one section of 9 m pipe and gallery at a time and partially backfilled to within a few meters from the upstream end. When the excavators had advanced to about 280 meters a cat was brought in to push in the remainder of the side cast.

The outlet of the pipe was kept separate from the rest of the sediment pond with a berm (Figure 7). A sump hole was dug at the downstream end of the pipe, separated from the pond by a berm. A wire cage was placed in the sump hole and water pumped from the caged area to the sediment pond, keeping the ditch line water level to a below 30 cm. The cage kept the pumps from being clogged from wood debris flushed out while excavating. While the pumps were running, the ditch water 0.6 to 1 m below the pond water level. Over night, the pumps would be shut off and the berm breached slightly. By morning, the ditch water would have risen and would be flowing into the pond through the breach. An hour before work was to begin, the breach would be filled and the pumps started.



Figure 7: A pump was placed behind a berm on the downstream end of the intake pipe. This allowed the ditch to be drained for ease of pipe placement and minimum sedimentation.

The pipeline follows the toe of a hill on Hahn's field. The Lawrence Road is built up 2 m to prevent flooding. Where the hill and the road meet, the side cast had to be pushed back by the cat to allow room for the excavators to work. It took six days to lay the 300 m of pipe up to the control valve at the edge of the road prism.

### 3.1.3 Water Jump

The Hahn property is an equestrian center and the pipeline and pond are located in fields used for jumping. The landowner had hoped that he would be able to use the open channel in the original plans in his jumping course. This wasn't possible with the buried pipeline. To allow him a water jump, a 25 cm pipe was connected to the 600 mm pipe that diverts water to a water jump and then back to the sediment pond. The jump area is a 5 m x 15 m trench 1.5 m deep at the center tapering to ground level at the ends. Two sides are steeply slope and rocked while the north and south ends are low gradient to allow the horses to run through (Figure 8). There is 30 cm of water on the graveled bottom. The jump is located 30 m up the pipeline from sediment pond.



Figure 8: This water jump was dug 30m from the pond. It is connected to the pond by a 20 cm pipe that supplies water to the jump.

### 3.1.4 Control Valve

The control valve is located in a manhole on the north shoulder of Lawrence Road across from the intake structure (Figure 9).

The manhole consists of 3 – 1 m high concrete rings 107 cm (42”) in diameter. The bottom ring has an 8 cm concrete slab at the bottom. The top ring has a concrete lid with a lockable metal hatch. The valve is a simple steel plate with sides that allow it to slide over the last rib of the pipe (Figure 10). It is lifted and lowered manually with a handle welded to the back of the plate. It can be held open by a chain at 5 cm intervals (the length of a link). The concrete rings are fitted with rungs for access to the bottom of the manhole. If work has do be done on the valve, the water can be shut off at the intake structure by sliding a half sheet of plywood between the concrete and the grill.



Figure 9: The manhole housing the control valve is located on the north shoulder of Lawrence Road. The metal door is locked.



Figure10: The control valve being lowered over the end of the pipe during construction.

### 3.1.5 Intake Structure

The intake structure is a three-sided concrete structure with a bottom approximately 1.2 m high, 1.5 m wide and 1.5 m deep (Figure 11). There are two grills. One is placed on the back wall immediately in front of the pipe inlet that covers just the pipe (Figure 12).

There is a grill made of 75 mm rebar @ 150 mm centers that is bolted to the face of the intake. The grill is offset from the concrete face just far enough that a piece of plywood can be slipped in down in front of the pipe to shut off water in case the valve needs to be worked on. A second grill covers the entire front of the structure. This grill is hinged at the bottom of the structure and locked at the top. It can be unlocked and pushed forward to remove debris that has collected in front of the intake. The other, coarser grill extends from the bottom front of the structure to the top of the back wall. The large grill is hinged at the bottom and is locked in place. The lock can be opened and the grill pushed out for cleaning.

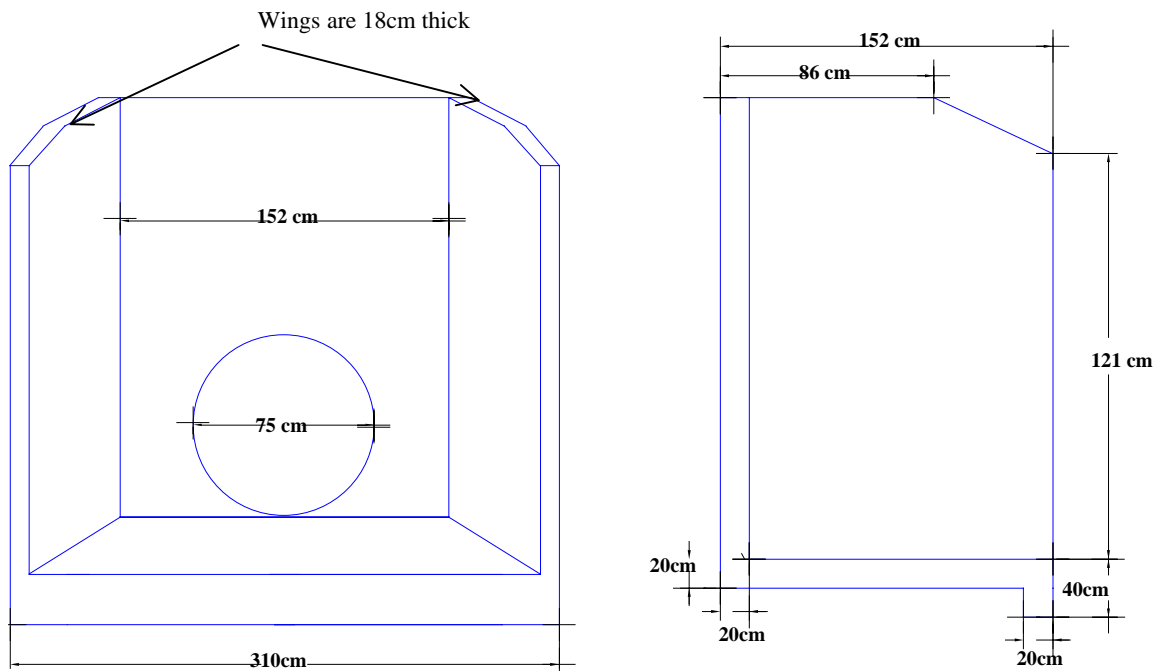

Figure 11: The intake structure.



Figure 12: The inside grill of the intake structure is fixed to the concrete for safety reasons it can only be removed with a cutting torch. A piece of plywood is blocking the pipe.

Because placing the intake was done outside of the normal work window, extreme care had to be taken with the sediment control when the riverbank was breached. Patrick Cochran, the engineering technologist from the Kamloops Habitat branch was able to be on site to help with the placement. Eight-foot lengths of 20 mm rebar were driven into the riverbed in a semicircle around the intake site. Lengths of rebar were wired to the tops of the upright pieces. A double layer of road fabric with 3/8" chain sewn along the bottom edge was draped over the rebar for a silt fence. This fence wasn't intended to be water tight but to merely slow down the flow of water going by the intake site. The pipeline would remain open when placing the intake and final section of pipe, drawing water into the line and creating a negative pressure within the area behind the silt fence. This negative pressure would prevent any silt from entering the river.

The pipe had previously been laid up to the manhole and backfilled before the road was breached. A 3 m piece of pipe had been fitted to the intake structure (Figure 13), so that once the structure was in place, only one section of pipe placed to complete the line.



Figure 13: A silt fence was placed in the river. The intake structure had a 3 m piece of pipe attached to it. The last section pipe to be installed connected the intake structure pipe to the manhole. This allowed about 30 cm of leeway.

The intake was placed after the trench was dug to the proper elevation (Figure 14). Two chains attached to the intake allowed the two excavators to level the intake with a great deal more ease than if only one excavator had been used. With the intake leveled, the berm between the river and the ditch could be restored and armoured. The final section of pipe was then attached and the trench backfilled.



Figure 14: The elevation is checked for the placement of the intake structure. Note the silty water on the inside of the curtain compared to the clear river water. The dirty water was drained down the pipeline during construction. Because the cold water would quickly incapacitate anyone who fell in, all the workers wore floatation jackets.

The road was backfilled and vibrated in 1 m lifts. The vibration did not significantly help with compaction. The trench through the road was backfilled with dry material but there was enough water in the trench to over-moisten the soil for good compaction (Figure 15). With the last section of pipe in place, the water couldn't drain down the line as the trench was filled. To give this section of the road support under these wet conditions, a load of

rock had to be added to the road prism. The road was topped with a layer of crush material and compacted.



Figure 15: With the last section of pipe in place, the water was not able to drain down the pipeline to the sediment pond. Much of the water could be bailed from the ditch to the field side of the road, but there still remained enough moisture in the backfill to make vibration ineffective. A load of rock was added to the fill to give support until the material was able to drain.

### 3.1.6 Road Prism

Lawrence Road was heavily ripped during a flood period approximately 10 years ago. The road was built up to stop overtopping by the river and the rock quickly placed to keep the newly raised roadbed from washing away. The riprap was placed at too steep an angle and has been falling into to the river. When placing the intake, WCRC pulled back the slope, moving the road prism over by 2 m (Drawings in Appendix I).

The fence on the Hahn's property had to be moved back as well. Thirty loads of rock were placed along the newly sloped road (Figure 16). Twelve loads of pit run were used

to widen the road prism and eight loads of crushed gravel were used to surface the road. Willow cuttings were planted during the placement of the riprap.



Figure 16: The existing riprap along Lawrence Road had been placed at a steep angle and had been deteriorating. Sixty meters of the road was pulled back 2m from the river to allow new rock to be placed at a more stable angle. Willow stakes were planted in with the rock. Work was done outside the window and without working in the water.

### 3.1.7 Crossings

There were six existing crossings along the remnant channel before construction. One crossing was a wooden bridge structure that had collapsed and was spanned only by one wooden plank for foot passage. Three of the crossings had culverts that were not functioning and one crossing was log corduroy. Only one of the existing crossings had a functional culvert.

WCRC upgraded these crossings with steel pipe arches (Figure 17). An additional crossing was also put in at the end of the sediment pond on the Hahn/Affolter property line. This crossing provided access across the channel for both properties. A 12 m 1390

mm x 970 mm pipe was used at the uppermost crossing. For crossing farther downstream on the channel either two 1390 mm x 970 mm pipes or a single 2130 x 1400 mm was used to accommodate the additional groundwater flow. The single larger pipe arch would be preferable because there is less chance of plugging with debris or being dammed by beaver. However, on some crossings the surrounding fields are only slightly higher than the water level. To build the road high enough to accommodate the larger culvert would make the crossing higher than the adjoining fields. During flood periods this would force the water to flow through the fields instead of over the armoured crossing.



Figure 17: The JD 790 lifts a 2130mm x 1400mm x 12m steel pipe arch to placed it at a channel crossing. The culverts were assembled on the flat and lowered into place. The unseasonably dry weather allowed this work to be done in the dry.

Table 2: Culverts used on the Procter Channel

Site	Number	Size (mm)	Length (m)	Unit Cost*
Hahn/Affolter Property Line	1	1390 x 970	12	\$2,593.78
Middle Affolter	0	-	-	0
Affolter/Chambers	1	2130 x 1400	10	\$4,696.05
Chambers	2	1390 x 970	10	\$5,187.56
Chambers/459218BC Ltd	2	1390 x 970	10	\$5,187.56
459218BC Ltd	1	2130 x 1400	12	\$4,696.05
459218BC Ltd	2	45 (round)	8	\$200.
Procter	2	1390 x 970	10	\$5,187.56
Total	11			\$27,748.56

\*Before taxes

At each crossing a swale was made and armoured with rock. In the event of a high flood year, the water will overtop the crossing. The area where it spills over is gently sloped and armoured on the downstream side to prevent erosion.

On one of the crossing on the Affolter property, no culvert was used. The original crossing here was made from log corduroy. At this site the adjoining fields were less than 30 cm above the new water level. If a pipe arch had been placed here the road would either have to be built up over a meter or the pipe buried a meter below the channel bottom. If the road way were to be built up higher than the surrounding fields, floodwater would be forced through the fields rather than over the crossing. If the pipe were buried low enough so the roadway was not built above the fields, it would gradually fill in with sediment and the water simply flow over the road. Instead of placing culverts, the corduroy was removed and the crossing armoured. First a 30 cm layer of 8-inch minus was laid down followed by 1-inch gravel. This was vibrated in using the vibrating head on the John Deere 670 in such a way that the water flows in two separate streams on either side of the crossing. The metal pipe gate was placed in the middle of the crossing. The gate would normally remain closed allowing animals to water from either side of the channel. If the gate is opened, the channel can be crossed (Figure 18).



Figure 18: The middle crossing on the Affolter property doubles as an armoured watering site. With the gate in the center closed, animals can access the water from either side of the crossing. With the gate open, the channel can be crossed. A layer of rock was topped with a layer of gravel to prevent sedimentation of the channel.

### 3.1.8 Refuge holes and Spawning Runs

Refuge holes and spawning runs were dug in areas where the excavators could access the channel without disturbing the existing trees or shrubs. The refuge holes averaged 5 m in diameter and 2 m in depth. The shape varied depending channel width and on the reach of the excavator. Material taken from the holes was placed nearby in mounds with the sod on top. These mounds will be planted with trees in spring. Roots and other woody debris were placed in the holes.

The spawning runs were where the channel was narrow enough to create a strong enough current to keep the gravel clean. These bottlenecks were limited to the crossings in the upper two kilometers of the channel. In the lower half of the channel, there were more

existing narrows. In some constricted areas there was gravel just below the sod. In other areas, gravel was placed downstream of the refuge holes. When digging the holes, the excavator would remove a bucket width (~2m) of organic material approximately 10 m downstream of the hole. The gravel taken from the hole was spread 0.4 m deep along this trench. Fourteen of these refuge holes and associated spawning channels were dug.

### 3.2 Planting

The majority of the riparian corridor along the Procter Channel has established vegetation. The merchantable timber has been removed for the most part; there is a good cover of deciduous trees and shrubs with a scattering of cedar and spruce. There were areas, however where the fields were cleared right to the cattails. There were also areas that were disturbed during construction. These were the areas of the most concentrated plantings. A list of planting stock is given in Table 3.

Table 3: A list of the species planted.

Common Name	Species	Type	#	Unit Price	Cost
White Spruce	<i>Picea glauca</i>	1m	56	\$15.00	\$210
White Spruce	<i>Picea glauca</i>	2m	6	\$35.00	\$840
Red cedar	<i>Thuja plicata</i>	3 yr	25	\$3.00	\$75*
Yellow cedar	<i>Chamaecyparis nootkantensis</i>	3 yr	2	\$10.00	\$20*
Paper birch	<i>Betula papyrifera</i>	3 yr	25	\$5.00	\$250*
Paper birch	<i>Betula papyrifera</i>	1yr	200	\$1.10	\$220*
Water birch	<i>Betula occidentalis</i>	3 yr	25	\$10.00	\$250*
Water birch	<i>Betula occidentalis</i>	1yr	200	\$10.00	\$250*
Aspen	<i>Populus tremuloides</i>	3 yr	30	\$10.00	\$300*
Cottonwood	<i>Populus balsamifera</i>	Cuttings	30	\$3.00	\$90*
Cottonwood	<i>Populus balsamifera</i>	Cuttings	50	Developed	on site
Chokecherry	<i>Prunus virginiana</i>	3 yr	3	\$7.00	\$21.
Chokecherry	<i>Prunus virginiana</i>	2 yr	50	\$5.00	\$250*
Alder	<i>Alnus crispa</i>	1 yr	500	\$1.10	\$550
Pacific willow	<i>Salix lucida lasiandra</i>	Stakes	2000	Developed	on site
Spirea	<i>Spirea pyramidata</i>	1yr	100	\$1.10	\$110
Hawthorn	<i>Crataegus douglasii</i>	3 yr	50	\$10.00	\$500*
Snowberry	<i>Symphoricarpos albus</i>	3 yr	35	\$10.00	\$350*
Pacific ninebark	<i>Physocarpus maluaceus</i>	3 yr	6	\$10.00	\$60*

Red Osier Dogwood	<i>Cornus sericea</i>	3 yr	25	\$7.00	\$175
Red Osier Dogwood	<i>Cornus sericea</i>	2 yr	50	\$3.50	\$175*
Red Osier Dogwood	<i>Cornus sericea</i>	1 yr	400	\$1.10	\$440
Rose	<i>Rosa spp</i>	3 yr	50	\$5.00	\$250*
Rose	<i>Rosa spp</i>	1 yr	160	\$1.10	\$176
Oregon grape	<i>Mahonia aquifolium</i>	3 yr	20	\$5.00	\$100*
Douglas fir	<i>Psuedotsuga douglasii</i>	3yr	10	\$10.00	\$100*
Spirea, Alder & Water Birch		1 yr	40	\$1.10	\$44*
Total					\$5806
Total In-kind					\$3284
Cost to BCRP					\$2582

\* In-Kind contribution from Plantashpere Projects Ltd.

\* In-kind contribution from Future Forests Ltd.

\* In-kind contribution from Tom Minor, WCRC

Plants were purchased from two local sources. Larger rooted stock was bought at Plantasphere, a small nursery in Lumby while Mary Fraser of Future Forests Ltd supplied one-year old stock. The owner of Plantashpere, Dr. Chris Marchant, propagates his native stock from locally gathered seed and cuttings. The nursery is not irrigated or fertilized so there is less shock after transplanting. Because the stock is bare root, holes are dug the previous day and soaked. Trees and shrubs are lifted in the nursery the following morning and planted that afternoon. The roots of the transplants are wrapped in plastic for transporting. Peat soil is packed around the root balls for transporting and used when planting if soil conditions at the site are poor. Bonemeal is worked into the holes before planting.

Several thousand Pacific willow cuttings were made. Disturbed areas were planted heavily as the excavation work was being done (Figure 19). The willow was collected locally in February.



Figure 19: When the above refuge pond was dug, the soil was placed along side the channel and heavily planted with Pacific willow before the soil froze. Later in the spring rooted stock was also planted.

Because willows are so quick to grow, it is hoped that by planting the disturbed areas heavily they will out compete invasive weeds.

Willow is the cheapest and easiest of the trees and shrubs to plant. It can also be cut back drastically and sprout new growth. For these reasons, it was the most heavily planted species. If the riparian exclosure fence is breached and livestock browse the new plantings, there is less of a loss. Spruce and cedar can always be planted later if the animals are kept out of the planted areas and more diversity is needed. Spruce and cedar will, in fact, do better if grown in partial shade.

The willows were often planted in groups of three or four to encourage a shrub form rather than a tree. The smaller diameter stems of the shrub form are less susceptible to beaver damage. Also, by planting in tight groups, voles are not able to completely gird a single stem. They can remove the bark around the outside of the group, but are unable to get

between the stems. These tight groups can be planted without vole guards. Areas where there was no riparian cover were also planted with willow as well as other rooted stock.

### 3.3 Fencing

Approximately 6 kms of riparian enclosure fence were built. The type of fence varied to match the existing fencing. The different types are shown in Table 4.

Table 4: Fencing Types Constructed along the Procter Riparian Corridor

Property	Type of Fence	Length (m)
Hahn	3 rail with 2 strands electric wire	250
Affolter	Page wire with top rail	1200
Chambers	5-strand barbed wire	900
Unwin	Page wire with top rail	230
459218 BC Ltd	Split cedar rails/ 4-strand barbed wire, 1-strand high tensile.	3100
Procter	None	0
Huwer	7-strand high tensile	150
<b>Total</b>		<b>5830</b>

The Hahn property is used for cross-country horse riding with the owner holding clinics for different levels of expertise as well as competitions. The rail fence was constructed using plastic cups to hold the rails to the posts (Figure 20). If a horse or rider were to fall onto a rail, the rail would pull out of the cup, reducing the chance of injury.



Figure 20: A rail fence was built on the Hahn property to match the existing fence. Plastic cups are used to attach the rail to the post to lessen the chance of injury to the horse or rider. Holes are drilled through the post and electric wires are run between the rails.

Both the Affolter and Unwin properties were fenced with page wire with a top rail. Page wire was requested because the landowners anticipated keeping sheep in the fields adjoining the channel. One of the difficulties using page wire is that it acts as a barrier to most wildlife. Larger deer can jump the fence but fawns will look for a way under the fence often making them susceptible to predation. Bear will struggle with the fence, eventually pulling it down trying to get through or over it. In an attempt to remedy this, rails located 35 cm and 90 cm above the ground were placed on some sections of the fence. The bottom of the page wire was cut and lifted to the bottom rail and the top of the page wire was cut and lowered to the top rail to allow limited passage under and over the fence at these sections (Figure 21). These sections were placed where game trails were evident during the winter. An additional one was added in June where there were signs of animals trying to pass through the unaltered fence. These railed sections double as climb-overs for human access into the riparian area as well.



Figure 21: On some sections of the page wire fence, rails were added. The top of the wire was lowered and the bottom of the wire was raised to allow passage of wildlife such as fawns and bears.

The Chambers and limited company properties both are used for pasturing cattle and barbed wire was used. On both properties the Hesketh method of bracing was used. This is a 3-post brace with a brace placed at the end of every section of wire (Figure 22).

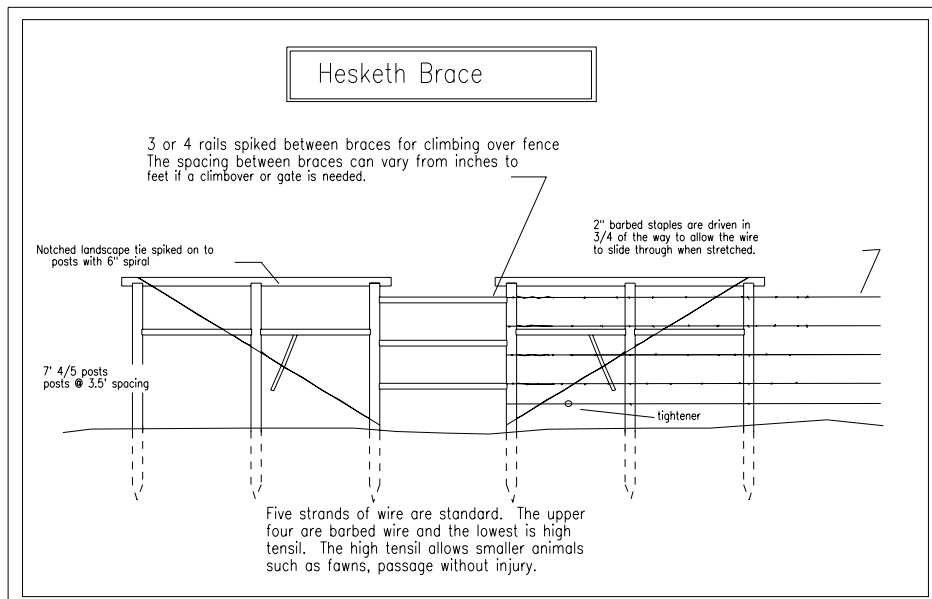

Figure 22: The Hesketh brace used on barbed and high tensile wire fences.

Whenever there is a change in direction of the fence line, a new section of wire is started. At any change in the fence direction therefore, there are two braces with a gap in between the braces. By using this method, the wire is only stretched in one direction. When a continuous fence is tightened any bend in the fence line creates a sideways pull on the fence posts at the bend. Because the fence is not braced against lateral tension, the posts are eventually pulled over and the fence slackens.

The gap between the two braces is most often spaced about a meter with three or four rails joining the two braces. The rails make a convenient climb-over and don't translate lateral tension. In some cases, a larger gap is left and a gate place between the braces (Figure 23).



Figure 23: The braces shown above were placed wide enough apart to allow a wire gate to be placed in between. In addition to the gate, sections of rails were also used. The rails offer strength at a point of concentration if cattle have to be moved through and a climb-over for quick access into the riparian enclosure.

## 4.0 Results

Overall, the results of this project are excellent:

- the project was completed on time
- the project was completed within the budget,
- the landowners appear to be pleased with the results,
- in May and June, fry as well as larger (20 cm) trout could be seen in both the upstream and downstream kilometer of the channel,
- the water levels were where they were predicted to be with no unexpected flooding and
- the water is clear even when the river is turbid.

This project had a slow start. Landowner negotiations took longer than expected for several reasons. The landowner agreement (Appendix 1V) went through so many changes that many of the property owners grew weary of signing the new editions. One landowner would think of something that they wanted included in the agreement and it would have to go back to the rest for consensus. Some of the landowner fears were:

- increased government influence/control of their property
- concerns that future staff would not honor an agreement with the current staff at the government agencies.
- loss of the use of productive land
- increased traffic on their property by government agencies and the public
- weeds
- additional work and expense
- increased flooding.

Another reason for the project's delay was the difficulty in contacting the landowners. One property is foreign owned. Contact had to be made through the lawyer who would forward the information to the owners. Other landowners were out of town much of the time, making it difficult to meet with them and especially difficult to assemble as a group.

It wasn't until December that all the landowners signed the agreement and work was able to begin. Fortunately, the mild winter allowed the work to be completed.

The delay in the start of construction did have a positive side. The water levels in the river were at a minimum, the remnant channel had, for the most part, gone dry and the groundwater level was as low as the landowners had seen it. This made construction easier and simplified the monitoring. There were a few holes where water remained that could be sampled for fish at the end of October. Live trapping resulted in several redbreasted shiners.

During the planning stages, there had been some debate on what type of pipe to use. Galvanized pipe is cheaper than the double walled plastic pipe and has been well tested. The plastic pipe had shown excellent strength in laboratory tests but has not been used in the field for as long as the galvanized product. The plastic pipe is lighter than the galvanized. This has both benefits and drawbacks. Two workmen can move distribute the pipe around the site with a pickup and maneuver it into place by hand, saving excavator time. However, the plastic pipe also floats and has to be weighted down when working below the water table. The ease in which the plastic pipe can be connected was the deciding factor. The plastic pipe has very simple joints, coming together with three plastic pull-ties in a matter of minutes. There is a considerable amount of play in the collars, allowing the pipe to be turned up to about 15°. The galvanized pipe, on the other hand, has to be closely aligned and bolted together. This requires an excavator to maneuver the pipe into position and can take hours even on flat ground. In a water-filled ditch in December, it would have been very difficult to make these connections.

The use of two excavators worked well for placing and burying the pipe. There was less traveling with the two machines and one could steady the pipe while the other backfilled. Having both machines to lower and position the intake also made things easier.

The placement of the infiltration gallery worked well. When the river gets turbid the intake valve can be closed. The pond level drops about 10 cm from the reduced flow

depending on the groundwater level. When river water is shut off, the infiltration gallery still supplies a clean flow, approximately 2 ft<sup>3</sup>/s (Figure 24).



Figure 24: This photo taken in mid-June shows the water flowing out of the sediment pond on the Hahn property. At the time, the river was high and the water turbid, with visibility to a depth of 30 cm. The intake valve is closed. The water flowing out of the pond is largely groundwater and clear with the infiltration gallery accounts for most of the flow. There is also infiltration from the sides of the pond.

Replacing the sod around the edges of the pond during excavation worked well. This is a practice that WCRC commonly used when doing stream stabilization work. The old sod quickly re-roots and prevents the banks from washing in during high flows or heavy rain. With the sediment pond there is the additional inflow of water from the high springtime water table. With the silty soil and low surface water level due to the closed intake, the pond is highly susceptible to erosion from groundwater flow (Figure 18). Without the sod placement, erosion would have been extensive.

WCRC made an effort to insure that the benefits of this project to each landowner outweighed the inconvenience incurred by the project and the other negative aspects of having this project go ahead. For example, Robin Hahn had his fields torn up to

have the pipe buried through his property plus there was heavy traffic through his property by pickups and machinery that trampled other fields during construction. In return, he got a pond that is well planted and improves on the aesthetics of the property. He also got a low spot in his fields filled with the spoil from the sediment pond and he got two riding jumps built. One of the jumps is a narrowing of the channel just upstream of the culvert at the Hahn/Affolter property line (Figure 25). The other is the 4 m x 15 m trench shown in Figure 8, p. 20.



Figure 25: This photo shows a spot of the pond shore where there was no sod placement. Groundwater is seeping in, eroding the silty soil. In the upper half of the photo, the sod is established and prevents this erosion.

Another example is the property owned by the limited company. They had several hectares excluded by the riparian fence. This area did not have a lot of grazing but did offer shade and some grazing/browsing for the cattle during the hot months. To compensate for this, WCRC made an effort to improving the property value when constructing the enclosure fence. Cedar rails were salvaged from a fence along the river. Duke Procter, the original owner, put up the fence around 1930. The fence had fallen but most or the rails were still usable. They were placed at the channel

crossings and around the barnyard. The combination of the new fence and restricting the cattle from trampling a small intermittent stream that flows through the yard, greatly improved the appearance of the property (Figures 26 a & b).



Figure 26a: Cattle have trampled this feeder creek to the Procter Channel to the point that there was no defined channel and vehicle access to the field was not possible except in very dry weather.



Figure 26b: The creek has been redefined, a culvert placed and an enclosure fence of salvaged cedar rails has greatly improved the appearance of this property.

WCRC also made an effort to involve the landowners as much as possible with the construction. While this wasn't possible with the absentee landowners, the resident owners were all involved to varying degrees. Robin Hahn help designed the layout of the sediment pond so that it fit in with the jumping courses that existed on his property. Darryl Squair was hired for the excavation work on the Chamber's property. He became quite enthused about developing habitat and donated as much excavator time as he was paid for. Leroy Procter was hired for tractor work on the Hahn property and to supply gravel to various sites when it was needed. He supplied tractor and skidder time and woody material to the work on his own property as an in-kind contribution. All the resident landowners were consulted about the type and placement of their fences and water access for their livestock.

This participation helped to cement the landowner buy-in and to promote ownership of the project. Once they became involved with the construction, the owners developed a more concrete vision of how they would like to see the end product and numerous ideas of how they could improve their operations.

The landowners were also encouraged to visit all the other properties to see what was being done. This was done to prevent any feelings of inequity and to gain an appreciation of the project as a whole.

WCRC will monitor the project over the next five years. Salmonid use will be monitored by periodic sampling with minnow traps, noting the species present, the type of habitat and the time of year. Temperature and dissolved oxygen levels will be recorded. Finally, the changes within the riparian enclosure will be recorded with established photo points.

Part of the success of this project was due to in-kind contributions from DFO, contractors and landowners. These contributions are summarized in Table 5.

Table 5: In-kind Contributions

Contributor	Service	Time (hrs)	Rate	Value
DFO	Surveying	50	\$60	\$3000.00
DFO	Mapping	30	\$60	\$1800.00
DFO	Design	24	\$80	\$1920.00
DFO	Site Supervision	16	\$50	\$800.00
Lee Hesketh, Cattleman's Association	Landowner Negotiations	40	\$50	\$2000.00
Tom Minor, contractor	Landowner Negotiations, Site supervision	80	\$40	\$3,200.00
Various (see p.25)	Plant Material			\$3,284.00
Len Foisey, contractor	Excavator	8	\$110	\$880.00
Andy Charest, contractor	Excavator	10	\$100	\$1000.00
Leroy Procter, landowner	Tractor, skidder	8	\$65	\$520.00
Leroy Procter, landowner	Plane	4	\$50	\$200.00
Darrel Squair, landowner	Excavator	20	\$100	\$2000.00
<b>Total</b>				<b>\$20,604.00</b>

## 5.0 RECOMMENDATIONS

WCRC has been working with government agencies, First Nations, local industry, forest companies and landowners on creek restoration work for the past seven years. Its goal has been to educate the public about the benefits of a healthy environment while creating jobs, training and stimulating the local economy.

WCRC has worked with over 30 landowners in the Lumby area, often turning skepticism of working with government agencies and of the benefits of environmental work to

acceptance and even enthusiasm. This landowner buy-in is essential for the success of any restoration project. Stewardship begins with the individual.

WCRC recommends that landowner and other stakeholder participation be further encouraged by the creation of a forum in which they could participate in the planning, monitoring and evaluating of the watershed restoration projects.

A roundtable in which landowners, local industry, forest companies and First Nations could participate in and work with government agencies would be beneficial in numerous ways. It would:

- improve coordination between agencies with jurisdiction and management authority within the watershed
- pool data and expertise and make it available to the public in easily understood laymen's terms
- provide a forum for community members to voice watershed concerns and seek assistance – better public access as well as exposing the stakeholders to constructive criticism and new ideas
- increase awareness of what is occurring within the watershed as well as in the different agencies of the local, provincial and federal governments.
- increase the educational component by involving schools and community groups
- have the projects prioritized for effectiveness on the basis of maximum ecological benefit and on the benefits to sustainable local community economics and revitalization
- work on the watershed as a whole, from the top down rather than piecemeal
- develop a broader base for drawing volunteers
- provide a broader basis for local fundraising
- maintain and increase landowner buy-in
- increase outside funding possibilities by having a broader base of support and plans in place.

The numerous benefits of a roundtable would greatly further WCRC's goal of creating a healthier local environment through education and public awareness and involvement while creating jobs and training opportunities.

## **REFERENCES**

Arc Environmental Ltd., 2001, Shuswap River fish/aquatic information review, prepared for B.C. Hydro, project No. 1180, Kamloops, B.C. V2C 6N6, pp 32 – 56

Armour, M., A. Bates, S. Clough, A. Gillespie, M. Wallis, G. Witzky, Stream Restoration Site Assessment Procedure for Southern Interior Streams (Version 2.0) 2001

Caverly, Alan, email to Fish Technical Committee, Thursday, October 18, 2001 7:42 PM,