



**Technical Interconnection Requirements
For Transmission Voltage Customers for Service
at 60,000 to 287,000 Volts**

V 1

October – 2019

Revision History

R	Date of Issue	Description of Revision	Name & Role
1.0	10-2019	1.0 Revision	Prep: Herman Kwan Rev : Herman Kwan Acpt: Sam Jones
			Prep: Rev: Acpt:
			Prep: Rev: Acpt:

Disclaimer

This document provides general technical interconnection requirements of BC Hydro for Customers that wish to connect to the BC Hydro Facilities.

This document is not intended as a design specification or as an instruction manual for constructing customer projects and shall not be used by Customers for those purposes. BC Hydro will provide the Customer with specific requirements for its interconnection project through Customer specific Interconnection Studies undertaken by BC Hydro at the request of the Customer. Persons using the information included in this document shall do so at no risk to BC Hydro, and they rely solely upon themselves to ensure that their use of all or any part of this document is appropriate in the particular circumstances.

Customers, their employees, contractors and agents, are solely responsible at all times for design, construction and operation of the Customer's Plant. BC Hydro does not represent, guarantee or warrant to any person, either expressly or by implication:

- (a) the accuracy, completeness or usefulness of,
- (b) the intellectual or other property rights of any person or party in, or
- (c) the merchantability, safety or fitness for purpose of,

any information, product or process disclosed, described or recommended in this document. Nor does BC Hydro represent, guarantee or warrant to any person, either expressly or by implication, that BC Hydro's requirements for a Customer's project meet all or any of the requirements of the law or other good engineering practices and standards which may be applicable to a Customer.

BC Hydro does not accept any liability of any kind arising in any way out of the use by a person of any information, product or process disclosed, described or recommended in this document, nor does BC Hydro accept any liability arising out of reliance by a person upon any information, statements recommendations or requirements contained or listed in this document.

BC Hydro's review of a Customer's design specifications and detailed plans is not a confirmation or endorsement of the engineering or design of a Customer's project, and is not a warranty of the safety, durability or reliability of the Customer's Facilities.

The information contained in this document is subject to change and may be revised at any time. BC Hydro should be consulted in case of doubt on the current application of any item.

1.INTENT, SCOPE AND LIMITATIONS	5
1.1 Intent.....	5
1.2 Scope	5
1.3 Limitations	6
2.DEFINITIONS	6
3.General Requirements	9
3.1 Safety Isolation	10
3.2 Point of Interconnection Requirements.....	10
3.3 Other Interconnection Considerations.....	16
4.System Performance Requirements	17
4.1 Frequency, Voltage and Harmonics	17
4.2 Insulation Coordination	21
4.3 System Dynamic Performance and Reliability	21
4.4 Load Shedding	22
4.5 Remedial Action Schemes	22
4.6 Customer load Requirements	22
5.Station Requirements.....	23
5.1 General.....	23
5.2 Station Insulation Requirements	23
5.3 Clearances.....	24
5.4 Transformer Requirements	24
5.5 Circuit Breaker Requirements	24
5.6 Substation Grounding	25
5.7 Standby Generation	25
6.Transmission Line Requirements.....	26
6.1 Transmission Line Insulation and Grounding Requirements.....	26
6.2 Transmission Line Design Requirements.....	27
7.Protection Requirements	27
7.1 Internal Fault Protection.....	27
7.2 Equipment Rating.....	28
7.3 Unbalance and Undervoltage	28
7.4 Entrance Protection.....	28
7.5 Transmission Line Protection Requirements.....	30
7.6 Under Frequency Load Shedding Protection	30
7.7 Batteries/Chargers/DC Supplies	31
8.Telecommunications Facility Requirements	32
8.1 General.....	32
8.2 Telecommunications Media	33
8.3 Telecommunications System for Operating Functions.....	33
8.4 Telecommunications System for Teleprotection Functions	34
9.System Operating Requirements.....	34
9.1 Normal and Emergency Operations.....	34
9.2 Telemetry and Telecommunications	34

10. COMMISSIONING REQUIREMENTS	35
10.1 GENERAL	35
10.2 CERTIFICATION OF THE CUSTOMER'S FACILITIES	35
10.3 PROTECTION EQUIPMENT.....	36
10.4 UNDER FREQUENCY LOAD SHEDDING	36
10.5 TELECOMMUNICATIONS EQUIPMENT	36
10.6 OPERATING, MEASUREMENT AND CONTROL SYSTEMS COMMISSIONING REQUIREMENTS	37
10.7 TRANSMISSION LINE	37
11. MAINTENANCE REQUIREMENTS	37
11.1 GENERAL	37
11.2 SCHEDULED OUTAGES REQUIREMENTS	37
11.3 PREVENTIVE MAINTENANCE REQUIREMENTS	38
11.4 PROTECTION AND TELECOMMUNICATIONS EQUIPMENT	38
11.5 RELIABILITY REQUIREMENTS	38
12. OTHER REQUIREMENTS	38
13. REFERENCES	38
13.1 BC HYDRO.....	38
13.2 CANADIAN STANDARDS ASSOCIATION	39
13.3 INSTITUTE OF ELECTRICAL AND ELECTRONICS ENGINEERS (IEEE) STANDARDS (WWW.IEEE.ORG).....	39
13.4 WECC GUIDELINES (WECC WEBSITE).....	40
13.5 OTHERS	41
APPENDIX A TRANSMISSION INTERCONNECTION INFORMATION REQUEST FORM	42
APPENDIX B BC HYDRO LOAD DATA AND MODELLING REQUIREMENTS	47
APPENDIX C BC HYDRO INSULATION COORDINATION PRACTICES	52
APPENDIX D BC HYDRO HARMONICS CONTROL REQUIREMENTS	61
APPENDIX E BC HYDRO VOLTAGE FLICKER PRACTICES	74
APPENDIX F CUSTOMER SCADA DESIGN PROCEDURE	81
APPENDIX G REMEDIAL ACTION SCHEME REQUIREMENTS.....	81

1. INTENT, SCOPE AND LIMITATIONS

1.1 Intent

BC Hydro has prepared this document to replace existing “Guide and Requirements for Service at 69,000 to 287,000 volts R0.2 September – 2011” document. It provides general technical interconnection requirements for connecting the Customer’s Facilities to the BC Hydro Facilities between 60 kilovolts (kV) and 287 kV. The purpose of this document is to:

- (a) facilitate compliance and compatibility of the Customer’s Facilities with BC Hydro standards and practices for safe operation, integrity, reliability and power quality of the BC Hydro Facilities;
- (b) provide information to the Customer for the planning, design, construction and commissioning of the Customer’s Facilities in order to ensure that impacts to the BC Hydro Facilities operation and reliability are acceptable to BC Hydro;
- (c) facilitate the efficient exchange of information between BC Hydro and the Customer relevant to planning, design, construction and operation of the Customer’s Plant and required to conduct Interconnection Studies; and
- (d) provide the minimum technical requirements the Customer’s Facilities must meet, and identify expected system conditions the Customer’s Facilities could encounter while connected to the BC Hydro Facilities.

1.2 Scope

This document applies to all Customers connected or wanting to connect to the BC Hydro Facilities.

The technical interconnection requirements contained in this document also apply to Customer’s Facilities with Standby Generation that will not be electrically connected to the BC Hydro Facilities directly or indirectly at any time (i.e. Customer generation connected under islanding conditions only). Where the Customer’s Facilities contain generation facilities that could operate in parallel to the BC Hydro Facilities at any time, the requirements of the “*60kV to 500kV Technical Interconnection Requirements for Power Generators*” shall also apply.

This document is subject to change in accordance with industry events and evolving standards. Technical interconnection requirements contained in this document are consistent with BC Hydro’s current practices for system additions and modifications. In establishing these requirements, BC Hydro considers the principles and practices of the following, as may be added to or amended from time to time:

- (a) North American Electric Reliability Corporation (NERC);
- (b) Western Electric Coordinating Council (WECC);
- (c) Canadian Standards Association (CSA);
- (d) Institute of Electrical and Electronics Engineers (IEEE);

- (e) American National Standards Institute (ANSI);
- (f) International Electrotechnical Commission (IEC);
- (g) British Columbia Utilities Commission (BCUC) Mandatory Reliability Standards MRS;
and
- (h) Good Utility Practice.

BC Hydro reserves the right to take whatever measures are necessary, in its sole discretion, to ensure the safe and reliable operation of the BC Hydro Facilities.

1.3 Limitations

The technical requirements contained in this document are intended to protect the BC Hydro Facilities but cannot be relied upon to protect the Customer's Facilities under all circumstances.

The Customer shall refer to:

- (a) "*Requirements for Customer Owned Primary Services Supplied at 4 kV to 35 kV*" for primary substations connecting to the BC Hydro distribution system at 4kV to 35kV, available online at:
<https://app.bchydro.com/accounts-billing/electrical-connections/distribution-standards/LA-Primary-Guide-2017.html>

and
- (b) "*60 kV to 500kV Technical Interconnection Requirements for Power Generators*" for power generators connecting in parallel to the BC Hydro Facilities, available online at:
<https://www.bchydro.com/content/dam/BCHydro/customer-portal/documents/transmission/tgi/technical-interconnection-requirements-for-power-generators-r14-2014-06.pdf>

2. DEFINITIONS

In this document, unless the context otherwise requires:

- (a) "**Basic Transmission Extension**" or "**BTE**" means the additions and alterations to BC Hydro Facilities, including switches and circuit breakers, necessary to extend up to 90 meters to the Transmission Line, as shown in the Facilities Agreement;
- (b) "**BC Hydro**" or "**BCH**" means the British Columbia Hydro and Power Authority, a British Columbia Crown corporation having an office at 333 Dunsmuir Street, Vancouver, British Columbia V6B 5R3.
- (c) "**Control Centre**" means BC Hydro's primary control centre (Fraser Valley office) and backup control centre (South Interior office) through which it operates the BC Hydro Facilities, and the BC Hydro distribution and generation systems.

- (d) “**Customer**” means a customer who takes or is proposing to take Electricity from BC Hydro pursuant to an Electricity Supply Agreement on the terms and conditions of rate schedule 1823 and others as amended or replaced from time to time.
- (e) “**Customer’s Facilities**” means the transmission and substation equipment owned by the Customer required for the supply of electricity to the Customer’s Plant, which may include the Transmission Line.
- (f) “**Customer’s Facilities Withstand Capability**” means the ability of the Customer’s Facilities to perform as designed during a power system disturbance.
- (g) “**Customer’s Plant**” means the manufacturing or other plant of the Customer, other than the Customer’s Facilities.
- (h) “**Demand**” means the power demand of the Customer’s Plant, as measured in kV.A.
- (i) “**Electricity Supply Agreement**” means the Electricity Supply Agreement entered into between BC Hydro and a Customer for the supply of electricity to the Customer’s Plant, in the form of Tariff Supplement No. 5 to BC Hydro’s Electric Tariff, as amended from time to time.
- (j) “**Emergency**” means any condition where, whether by reason of a forced outage or concern for a forced outage, or otherwise, there is an imminent risk of equipment failure, or of danger to BC Hydro or Customer personnel, the public or others, or a risk to the security or reliability of the Customer’s Facilities, the BC Hydro Facilities or any other generation, transmission, distribution or other electric system interconnected with the BC Hydro Facilities or the Customer’s Facilities.
- (k) “**Facilities**” means transmission and substation equipment
- (l) “**Facilities Agreement**” means the Facilities Agreement between a Customer and BC Hydro, in the form of Tariff Supplement No. 6 to BC Hydro’s Electric Tariff, as amended from time to time.
- (m) “**Good Utility Practice**” means any of the practices, methods and acts engaged in or approved by a significant portion of the electric utility industry in the WECC region during the relevant time period, or any of the practices, methods and acts which, in the exercise of reasonable judgment in light of the facts known at the time the decision was made, could have been expected to accomplish the desired result at a reasonable cost consistent with good business practices, reliability, safety and expedition. Good Utility Practice is not intended to be limited to the optimum practice, method or act to the exclusion of all others, but rather to be acceptable practices, methods or acts generally accepted in the WECC region.
- (n) “**High Voltage**” means a voltage level above 50 kV.
- (o) “**IEC**” means the International Electrotechnical Commission or its successors.
- (p) “**IEEE**” means the Institute of Electrical and Electronics Engineers or its successors.

- (q) “**Interconnection Studies**” means any assessments, investigations and studies required in order to assess the suitability of the Customer’s Facilities for interconnection to the BC Hydro Facilities and to identify any potential impacts arising from the interconnection, and may include a conceptual review, a feasibility study, a system impact study and a facilities study.
- (r) “**Islanded**” means a portion of the BC Hydro Facilities consisting of load and generation, which has become isolated from the BC Hydro Facilities due to the tripping of Facilities elements.
- (s) “**NERC**” means the North American Electric Reliability Corporation or its successors.
- (t) “**Operating Order**” means BC Hydro management’s standing instructions to operators and field workers (both BC Hydro and Customer) regarding electric system operation.
- (u) “**Peak Demand**” is the Demand which BC Hydro agrees to study, as determined in the Interconnection Studies.
- (v) “**Point of Interconnection**” or “**POI**” means the physical point of connection between the Customer’s Facilities and the BTE, unless otherwise specified by the Customer and BC Hydro.
- (w) “**Power Factor**” means the ratio, expressed as a percentage, of kW to kV.A when both are measured simultaneously over a specified time interval.
- (x) “**Power Generating Facility**” means a plant/site where generating and related Facilities, protection, control and telecommunications facilities are installed, which is connected to and in synchronism with other generators connected to the BC Hydro Facilities for the purpose of producing electricity.
- (y) “**Remedial Action Scheme**” means a scheme designed to detect predetermined System conditions and automatically take corrective actions that may include, but are not limited to, adjusting or tripping generation (MW and MVAR), tripping load, or reconfiguring a System(s). RAS accomplish objectives such as:
- Meet requirements identified in the NERC Reliability Standards;
 - Maintain Bulk Electric System (BES) stability;
 - Maintain acceptable BES voltages;
 - Maintain acceptable BES power flows;
 - Limit the impact of Cascading or extreme events.
- As described in Glossary of Terms of NERC Reliability Standards.
- (z) “**Standby Generation**” means a Customer’s generation with no parallel connection to the BC Hydro Facilities.

- (aa) “**Transmission Line**” means the transmission line that runs between the BTE and the Customer’s substation.
- (bb) “**Voltage Dip**” means a temporary drop (more than ½ cycle, less than a minute) in voltage magnitude below a predefined threshold (typically 90%) of the nominal voltage. When the low voltage extends longer than a minute it falls into the category of Voltage Variation, and events shorter than ½ cycle are classified as Voltage Transients.
- (cc) “**Voltage Fluctuation**”, including voltage flicker, means a rapid voltage change in fundamental frequency voltages over several cycles. The rapid voltage changes could also be in the form of cyclic changes (voltage flicker). Note: Voltage Fluctuations are normally caused by start-ups, inrush currents or switching operations of equipment.
- (dd) “**Voltage Swell**” means a temporary increase (more than ½ cycle, less than a minute) in voltage magnitude that exceed a predefined threshold (typically 110%) of the nominal voltage. When the High Voltage extends beyond one minute it is covered by Voltage Variation guidelines, and events shorter than ½ cycle are classified as Voltage Transients.
- (ee) “**Voltage Transients**” means voltage disturbances of very short duration, less than one half cycle (8 milliseconds). Voltage Transients are difficult to characterize, as they may have complicated and varied shapes, including voltage spikes, oscillating waves, or notches where the voltage drops for a fraction of a cycle. Small magnitude voltage transients or high frequency signals (a few volts or less) are usually classified as noise.
- (ff) “**Voltage Variation**” means a persistent variation in the fundamental frequency supply voltage, averaged over 10 minutes.
- (gg) “**WECC**” means the Western Electricity Coordinating Council or its successor.

3. GENERAL REQUIREMENTS

The Customer will communicate directly with all regulatory and governmental authorities in order to ensure that the Customer’s Facilities are designed, constructed, commissioned, operated and maintained in compliance with all applicable laws, standards, regulations, by-laws and codes.

Prior to undertaking any alterations to the Customer’s Facilities (i.e. design stage), the Customer shall submit details regarding the alteration to BC Hydro. Alterations that affect the Customer’s performance include station configuration, equipment rating, load characteristics (in particular magnitude, power factor, dynamic performance, data and modelling), control and protection schemes. Based on the details provided by the Customer, BC Hydro will conduct Interconnection Studies to determine how the alterations impact the system performance of BC Hydro’s Facilities and the requirements the alterations must meet.

The Customer may have a Power Generating Facility locally connected to its load facility for island mode operation, provided it is approved by BC Hydro.

3.1 Safety Isolation

BC Hydro and the Customer shall coordinate safety isolation for work on equipment at the Point of Interconnection and Customer's Facilities. The Customer is responsible for safety at the Customer's Facilities. BC Hydro is responsible for safety on the BC Hydro's Facilities. BC Hydro safety management systems include:

- (a) Power System Safety Protection; and
- (b) Safety Practice Regulations.

Areas of safety isolation coordination are:

- (a) the Point of Interconnection; and
- (b) BC Hydro metering equipment.

Safety and operating procedures for the isolating device shall be in compliance with WorkSafeBC and the Customer's safety management systems. Terms and conditions covering the control and operation of the disconnect device are normally covered by the Operating Order between the Customer and BC Hydro.

3.2 Point of Interconnection Requirements

The location of the Point of Interconnection will be established in the Interconnection Studies and Facilities Agreement. The location must provide suitable access to BC Hydro for operations purposes.

- (a) Isolating Devices

The Basic Transmission Extension will include one or more isolating device that must meet the following requirements:

- (i) It physically and visibly isolates the BC Hydro Facilities from the Customer's Facilities;
- (ii) It complies with WorkSafeBC safety and operating procedures;
- (iii) It is rated for the voltage and current requirements of the particular application;
- (iv) It is three phase gang operated;
- (v) It is operable under all weather conditions in the area;
- (vi) It is lockable in both the open and closed positions and able to accommodate multiple locks by use of a "scissor clip" type device;
- (vii) Its control and operation are determined by BC Hydro and described in the Operating Orders for the Customer's Facilities.

Additional isolating devices may also be required by BC Hydro at the BTE to provide line sectionalizing capability.

The isolating device is provided for isolation and cannot normally be used to interrupt load current. However, attachments may be required by BC Hydro to allow interruption of line charging current. BC Hydro will establish the location, capacity and operating rules for the isolating device in the Interconnection Studies.

BC Hydro prefers that the isolating device be placed within the BTE; however, it may be placed in a location other than the BTE if agreed to by BC Hydro.

BC Hydro personnel may lock the isolating device in the open position and apply tags:

- (i) for the safety protection of maintenance personnel when working on de-energized circuits; and
 - (ii) if the Point of Interconnection equipment or BC Hydro equipment present a hazardous condition.
- (b) General Constraints

The Customer's Facilities must not restrain BC Hydro from taking a transmission line, line section or other equipment out of service for operational and/or maintenance purposes.

The Customer will design the Customer's Facilities for operation at short circuit (fault) levels that take into account future development of the BC Hydro Facilities. BC Hydro will provide the short circuit levels at the Point of Interconnection, including future planned development.

(c) Interconnection Configurations

The connection method is site and system dependent. Thus, BC Hydro will determine the interconnection configuration for each application in the Interconnection Studies. The connection methods described below are examples of possible connection methods only and are not intended as a guide to the Customer for the appropriate connection method for the installation.

The BC Hydro Facilities at 230 kV and 287 kV is critical to system reliability in British Columbia and serves large geographical areas. As such, line taps pose a substantial risk to the BC Hydro Facilities at 230 kV and 287 kV.

Connection of a new Customer's Facilities onto the BC Hydro Facilities generally falls into one of the following three basic categories (in order of BC Hydro's preference):

- (i) *Basic Transmission Extension located within an existing BCH substation.*

As shown in Figure 1, this configuration includes a Transmission Line(s) built, owned and operated by the Customer. The Transmission Line(s) is terminated at an existing BC Hydro Facility modified to accommodate a new line position. Where redundant supply is required by the Customer, a second Basic Transmission Extension can be provided from the same or an alternate substation.

- (ii) *Connection by looping an existing transmission line (60 kV to 287 kV) into a new BC Hydro substation provided to terminate a Basic Transmission Extension for the Customer's Facilities.*

As shown in Figure 2, this configuration includes a Transmission Line built, owned and operated by the Customer. The Transmission Line is brought into a new BC Hydro Facility built to accommodate a new line position and two new transmission line terminations.

Where redundant supply is required by the Customer, a second Basic Transmission Extension can be provided. Where it is not practical to build a new station immediately adjacent to the existing transmission line right-of-way, the BC Hydro transmission line extensions are brought to the new station constructed nearer to the Customer's Facilities.

- (iii) *Connection into an existing BC Hydro transmission line (60 kV to 138 kV only) with one or two terminals via a tap.*

Generally, this installation is less desirable because of its negative impact on BC Hydro Facilities reliability and protection.

A BC Hydro transmission line with two terminals and a tap affects BC Hydro's ability to operate, dispatch, protect and maintain the BCH Facilities. BC Hydro will determine the permissibility of a tapped Transmission Line connection on a case-by- case basis in the Interconnection Studies. BC Hydro will define specific protection requirements for the Customer's Facilities terminal.

As shown on Figure 3, the isolating device for this application is required to have line charging current interrupting capability.

For one terminal transmission lines this interconnection will be assessed based on the impact on other customers on the line.

Figure 1: Case (i) – Basic Transmission Extension connecting to an existing BC Hydro substation

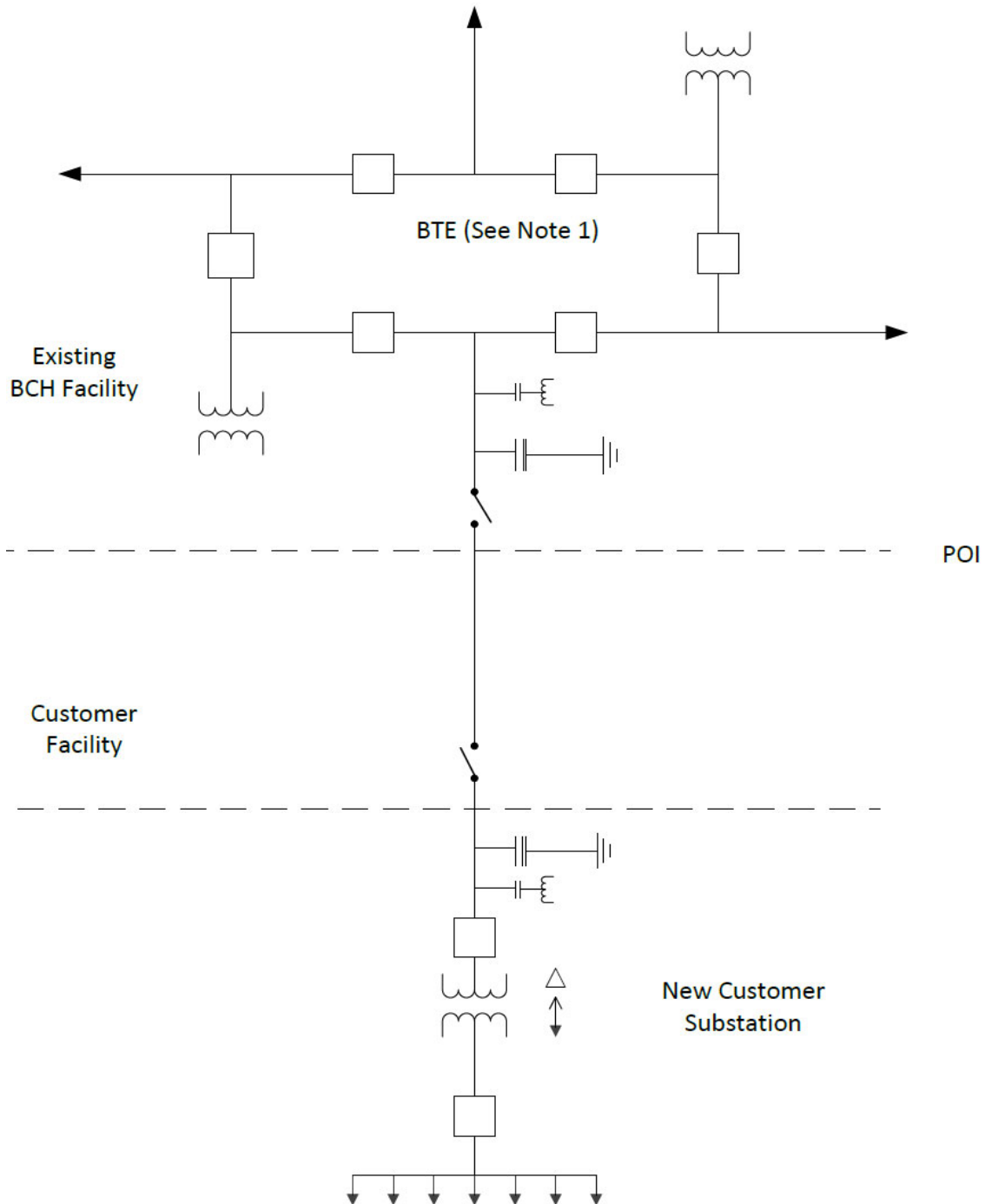

Figure 2: Case (ii) – Basic Transmission Extension connecting into existing Transmission Line

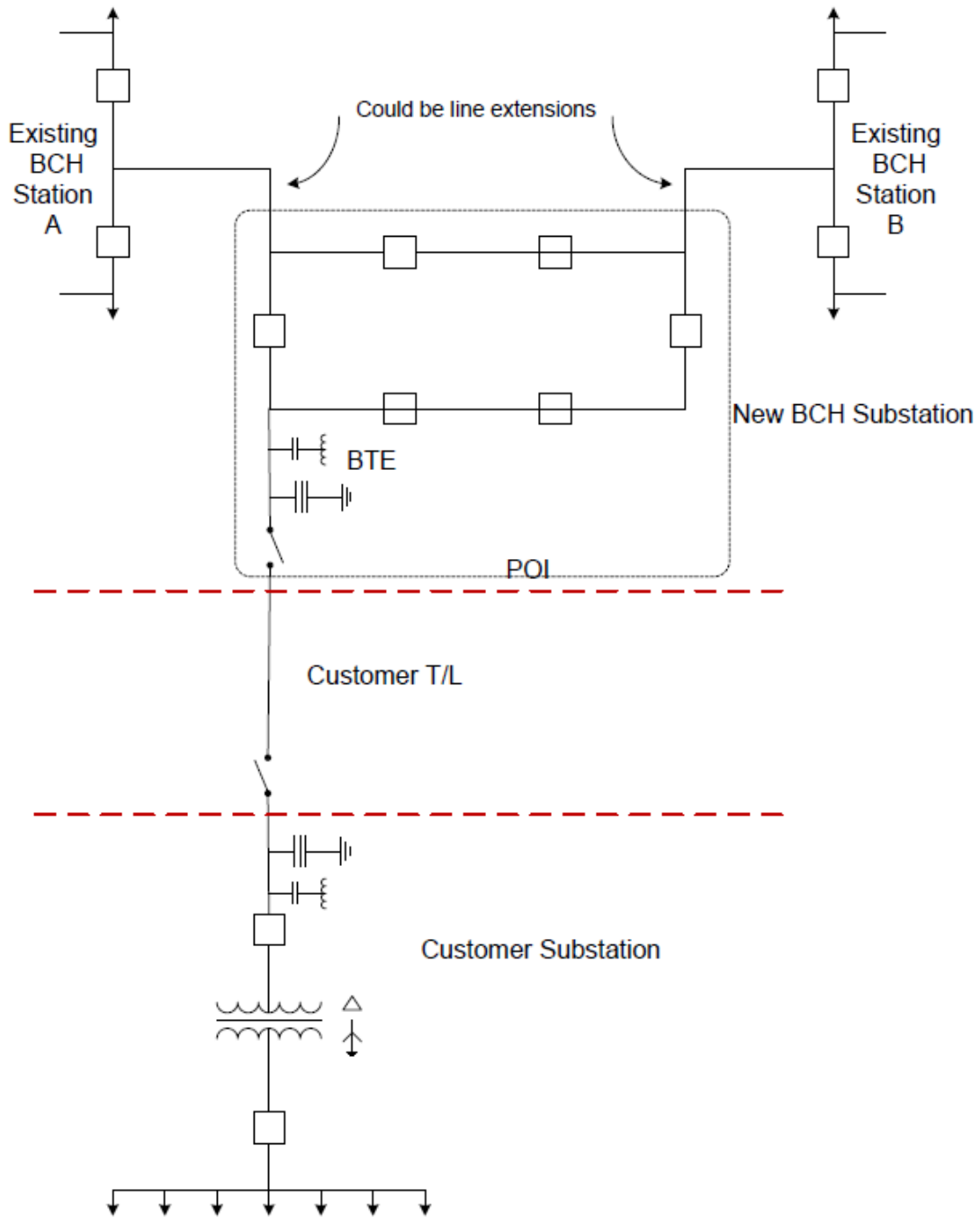
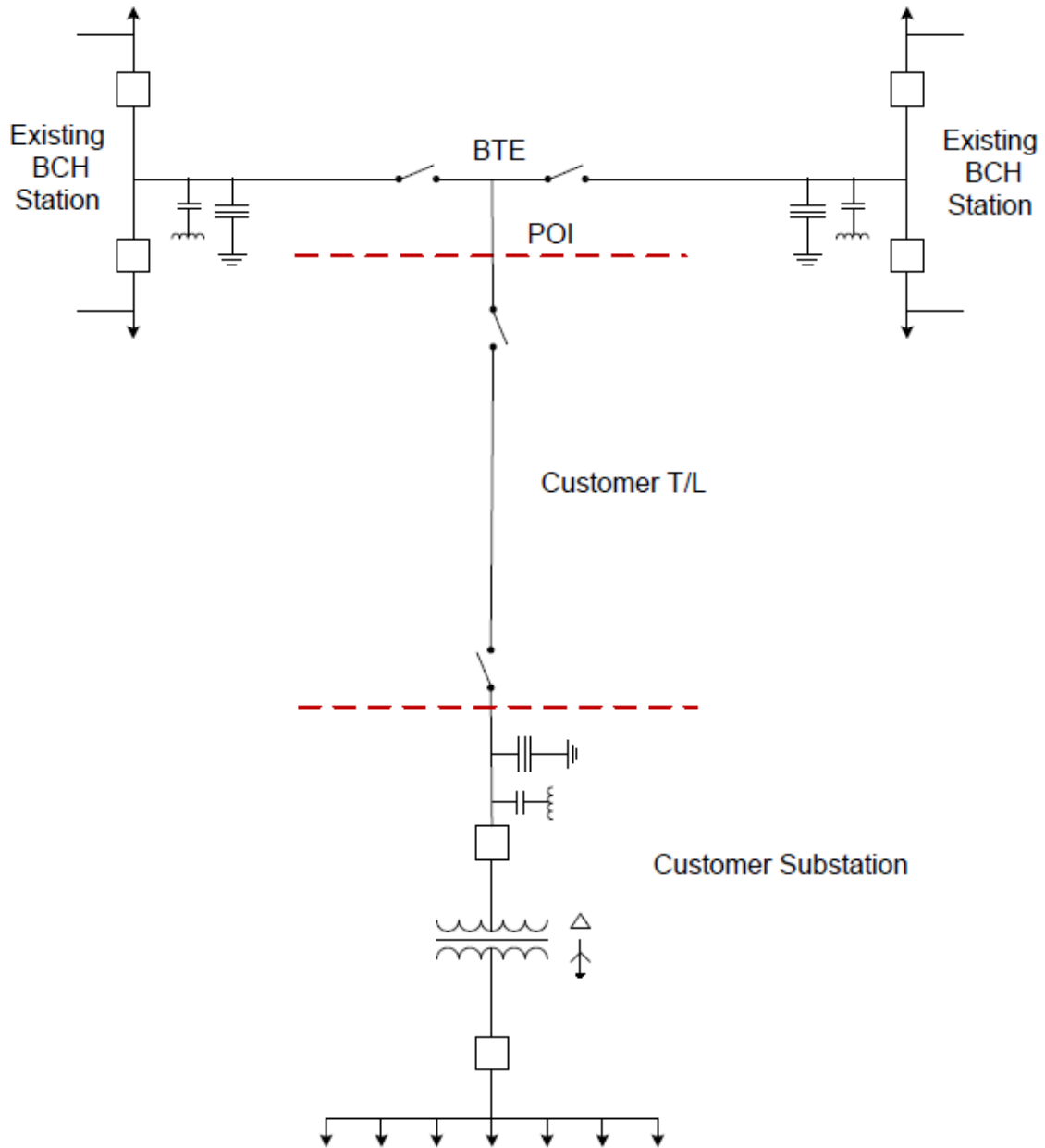

Figure 3: Case (iii) - Connection into an existing one or two terminal 60 kV to 138 kV transmission line via a tap.



3.3 Other Interconnection Considerations

(a) Existing Equipment

The proposed new connection may cause existing BC Hydro Facilities equipment such as transformers, power circuit breakers, disconnect switches, arresters, and transmission lines to exceed their ratings. Replacement of the impacted equipment or development of alternate plans of service will be part of the Interconnection Studies.

(b) Protection and Control

BC Hydro coordinates its protective relays and control schemes to provide for equipment protection and to minimize disruption of services during disturbances. New connections usually require addition or modification of protective relays and/or control schemes, at BC Hydro terminal stations. The Customer in turn is required to provide protection facilities which meet BC Hydro requirements. See Section 7 for greater detail.

BC Hydro reserves the right to perform a full set of acceptance tests prior to granting permission to use the selected protection scheme. Customer selected equipment must have interfaces compatible with BC Hydro equipment.

(c) Revenue Metering

It is important to incorporate revenue metering early in the planning phase of the Customer's Facilities. BC Hydro will install revenue metering equipment prior to connecting the Customer's Facilities to the BC Hydro Facilities. The location of the revenue metering equipment will be approved by BC Hydro during the design stage. The revenue metering must comply with BC Hydro's *Requirements for Complex Revenue Metering* (active), available online at: <https://www.bchydro.com/content/dam/BCHydro/customer-portal/documents/distribution/standards/ds-rmr-complex-revenue-metering.pdf>

(d) System Operations and Maintenance

New line and load connections must not restrict timely outage coordination, automatic switching or equipment maintenance scheduling. Preserving reliable service to all BC Hydro customers is essential and may require additional switchgear, equipment redundancy, or bypass capabilities at the Point of Interconnection for acceptable operation of the system.

(e) Power Parameter Information System

BC Hydro reserves the right to install a Power Parameter Information System at the Customer's Facilities to monitor power quality and steady state or dynamic performance. The Power Parameter Information System is capable of high-speed sampling to capture information such as harmonics, Voltage Dips and Voltage Swells, voltage and current levels. The information captured will allow BC Hydro and Customer staff to assess the condition of electricity at the Customer's Facilities.

(f) Customer Load Data and Modelling Requirements

The Customer shall provide complete models for each major component of the Customer's Facilities as outlined in the Transmission Voltage Customer Interconnection Data Form, attached as Appendix A. The load data and their associated models shall be validated by the Customer as required. See Appendix B, BC Hydro Load Data and Modelling Requirements, for possible testing requirements.

4. SYSTEM PERFORMANCE REQUIREMENTS

The following performance requirements provide additional details of the requirements set out in the Electricity Supply Agreement. These performance requirements can be satisfied by the Customer through appropriate documentation and/or test reports demonstrating compliance.

4.1 Frequency, Voltage and Harmonics

The relationship between electricity supply performance, the Customer's Facilities impacts on BC Hydro Facilities performance and the ability of the Customer's Facilities to withstand system disturbances is described in this section under the following three parameters:

- **BC Hydro Target** – the electricity supply performance is described by targets for each system performance characteristic. These targets are consistent with Good Utility Practice. The values are intended to provide information to the Customer to assist in the design of their facility to achieve acceptable plant performance.
- **Customer's Facilities Requirements** – the Customer's Facilities are expected to not create unacceptable disturbances on the BC Hydro Facilities due to plant operation. These unacceptable disturbances are considered equivalent to the term "Interference and Endangerment" used in the Electricity Supply Agreement. The Customer must control these unacceptable disturbances within specified limits in order to maintain the performance characteristic of the BC Hydro Facilities.
- **Customer's Facilities Withstand Capability** – on a long term basis, power system disturbances at or near the Point of Interconnection are inevitable. Depending on the Customer's location in the BC Hydro Facilities, the causes and the frequency of disturbances will vary.

The following is a list of the usual types of power system disturbances:

- sustained overvoltage;
- sustained undervoltage;
- sustained over frequency;
- sustained under frequency;
- impulse, spike, lightning or switching surges;
- excessive Voltage Fluctuation caused by starting of large motors;

- supply circuit forced outage; and
- Voltage Dips caused by remote faults.

It is important, therefore, for Customers to recognize that disturbances in the BC Hydro Facilities may adversely affect the operation of the Customer's Facilities. It is prudent for Customers to understand the nature of such disturbances and to take whatever action is possible to minimize the impact on their plants' electrical systems. For certain disturbances, Customer's Facilities Withstand Capability is also referred to as ride-through capability.

The following are typical characteristics of the BC Hydro Facilities and Customer's Facilities interconnection requirements:

(a) Frequency

BC Hydro Target - Frequency is typically 60 +/- 0.1 hertz (Hz). During under frequency situations load shedding will be required. WECC standard practices dictate that below 59.5 Hz for a certain period an under frequency load shedding is initiated.

Customer's Facilities Requirements – The Customer's Facilities are not expected to impact the system frequency under normal operating conditions. Under islanded operation, the Customer could affect the frequency of the islanded system depending on load size relative to the islanded system load. The Customer's Facilities shall participate in the BC Hydro under frequency load shedding scheme for loads greater than 5 mega-volt ampere (MVA).

(b) System Operating Voltage Ranges

BC Hydro Target – BC Hydro Facilities are not designed to provide precise voltage regulation at the Point of Interconnection. The BC Hydro Facilities operating voltage range is targeted to be +10%/-10% of nominal voltage under system normal operating conditions. Nominal voltages include 60 kV, 63 kV, 66 kV, 132 kV, 138 kV, 230 kV and 287 kV.

(c) Temporary Overvoltages

BC Hydro Target - For a description of temporary overvoltages refer to reference document "*BC Hydro Insulation Coordination Practices*", attached as Appendix C.

Customer's Facilities Requirements – The Customer's Facilities must not cause severe system temporary overvoltages (as characterized by magnitude and duration) by safe operating practices such as avoiding system resonances situations and abnormal network excitation conditions. Details of Customer's Facilities mitigation requirements are described in reference document "*BC Hydro Insulation Coordination Practices*", attached as Appendix C.

(d) Phase Unbalance

BC Hydro Target - Unbalanced phase voltages and currents can affect protective relay coordination and cause high neutral currents and thermal overloading of loads and motors. BC Hydro is targeting to supply a voltage at the Point of Interconnection with a maximum of 1.5% voltage unbalance (planning level) for systems 230 kV and above, and 2% (planning

level) for systems less than 230kV. A voltage unbalance is defined as the ratio of negative sequence voltage with respect to the positive sequence voltage.

Customer's Facilities Requirements - To protect the equipment of BC Hydro and third parties, the Customer's Facilities' contribution to the total unbalances at the Point of Interconnection must not cause a voltage unbalance greater than 1% for systems 230 kV and above and greater than 1.5% for systems less than 230kV or a current unbalance greater than 5%.

(e) Harmonic Voltage

BC Hydro Target - Harmonics can cause telecommunications interference and thermal heating in transformers; they can interfere and/or harm solid state equipment and excite resonant overvoltages. To protect equipment from damage, the Customer must manage and mitigate harmonics. Harmonic distortion is the ratio of the root mean square value of the harmonic to the root mean square value of the fundamental voltage or current. BC Hydro follows IEEE Standard 519 (active) with respect to harmonic voltage and current at the Point of Interconnection.

Customer's Facilities Requirements - The Customer's Facilities equipment shall not cause voltage and current harmonics on the BC Hydro Facilities to exceed the limits specified in IEEE Standard 519 (active). Single frequency and total harmonic distortion measurements may be conducted at the Point of Interconnection, or other locations on the BC Hydro Facilities to determine whether the Customer's Facilities equipment is the source of excessive harmonics. See reference document "*BC Hydro Harmonics Control Requirements*", attached as Appendix D for more information on harmonic control.

Customer's Facilities Withstand Capability – The Customer is expected to design their plant operation to accommodate harmonic distortion as described in IEEE Standard 519 (active).

(f) Voltage Fluctuations (including Voltage Dips and Voltage Swells)

A Voltage Fluctuation is a temporary drop or increase in voltage magnitude that are more than ½ cycle and less than a minute.

BC Hydro target - Voltage Fluctuations occurring on the BC Hydro system as a result of faults (due to lightning or equipment failure), equipment switching, load variations, generator dispatch and line switching are referred to Voltage Dips and Voltage Swells. BC Hydro follows Good Utility Practice in addressing these events. These Voltage Dips and Voltage Swells are statistical in nature with regard to frequency, magnitude and duration. Durations related to fault clearing times will range from four to 12 cycles for close in faults. High impedance faults may take seconds to clear.

Customer's Facilities Requirements - A Voltage Fluctuation is normally associated with the start-up of induction motors, energization of transformers or reactors, capacitor bank switching (energization and de-energization) or other equipment where a large inrush of starting current may cause the local system voltage to drop or rise. The Customer shall take steps to minimize Voltage Fluctuations caused by their plant operation.

Specifically, to maintain an acceptable level of power quality performance, the Customer shall ensure that phase-to-phase and phase-to-ground 60 Hz root mean square voltage change shall not exceed +5% and -6% compared to the immediately preceding one second average

value. The 60 Hz root mean square voltage value is calculated over any one 60 Hz cycle during the event.

The limits for acceptable Voltage Fluctuations at the Point of Interconnection are as shown in Table 1.

Table 1: Voltage Fluctuations

Voltage Change	Maximum Rate of Occurrence
+/-3% of normal level	Once per hour
+5/-6% of normal level	Once per 8-hour work shift
Exceeding +5/-6%	Only with written agreement by BC Hydro

(g) Voltage Flicker

Voltage Fluctuations occurring more frequently than once per hour will be referred to as voltage flicker. Voltage flicker can result in light flicker that can, at various frequencies and magnitudes, become irritating to the human eye. Voltage flicker is measured according to the standard IEC 61000-4-15 (active). Measurement parameters for voltage flicker are:

Pst – Short term flicker indicator which is the flicker severity measured over a short period (10 minutes). Pst = 1 is the industry accepted threshold of irritation

Plt – Long term flicker indicator which is the flicker severity measured over a long period (2 hours) using successive Pst values.

BC Hydro Target Values:

Pst < 1.0 more than 99% of the time

Plt < 0.8 more than 99% of the time

Customer Requirements – The Customer shall plan, design and construct the Customer's Facilities based on BC Hydro provided normal system fault levels to meet the following flicker requirements as determined at the Point of Interconnection:

Pst < 0.8 more than 95% of the time

Plt < 0.6 more than 95% of the time

See reference document "*BC Hydro Voltage Flicker Practices*", attached as Appendix E, for details on the process and study requirements.

In operation, the Customer's Facilities must meet the following voltage flicker requirements:

$P_{st} < 1.0$ more than 99% of the time

$P_{lt} < 0.8$ more than 99% of the time

(h) Voltage Variation

BC Hydro Target - Voltage Variation is a long term change in the steady state voltage. Voltage Variations are most commonly caused by capacitor, reactor or large load switching.

BC Hydro limits Voltage Variations to less than 5% of the operating voltage (planning level).

Customer's Facilities Requirements – Customer's Facilities must limit Voltage Variations to 5% at the Point of Interconnection once per 8 hour shift, or a value acceptable to BC Hydro.

4.2 Insulation Coordination

Voltage stresses, such as lightning or switching surges and temporary overvoltages, may affect equipment duty.

When Customer equipment is connected to the BC Hydro network, it must not degrade existing BC Hydro Facilities insulation performances and capabilities. In order to avoid potential problems, components for the new Customer's Facilities must have lightning, switching and temporary overvoltage performances that are comparable to the existing BC Hydro Facilities and follow the "*BC Hydro Insulation Coordination Practices*", attached as Appendix C.

BC Hydro power system equipment is designed to withstand voltage stresses associated with expected operation. Adding or connecting new facilities can change equipment duty, and may require that existing equipment be replaced or new switchgear, telecommunications, shielding, grounding and/or surge protection be added to control voltage stress to acceptable levels. Interconnection Studies shall include the evaluation of the impact on equipment insulation coordination. BC Hydro may identify additional requirements to maintain an acceptable level of BC Hydro Facilities availability, reliability, equipment insulation margins and safety.

4.3 System Dynamic Performance and Reliability

The BC Hydro Facilities has been developed with careful consideration for acceptable system dynamic performance and reliability during disturbances. The type of connection, size of the load, bus configurations, and load dynamic characteristics relative to the system where it is connected will affect the overall area performance. Should dynamic performance issues be identified, the Customer must participate in resolving the issues.

The Customer is responsible for determining and adequately designing and protecting the Customer Plant against the impacts of abnormal operations and Emergencies in the BC Hydro Facilities, such as the following:

- (a) Temporary overvoltage caused by large amounts of load rejections. Resonance or near resonance may occur when an islanded Facilities is left connected to the

Customer's Facilities. The temporary overvoltage may result in Customer's Facilities electric insulation damage.

- (b) Undervoltage caused by the lack of reactive power supply in the Customer surrounding area system under abnormal system operating conditions. It may result in unexpected load interruptions due to lack of undervoltage ride through capability.
- (c) Area system collapse or blackout caused by severe electric system contingencies
- (d) Deceleration of large Customer motors during system disturbances causing the plant to slip out of synchronism from the BC Hydro Facilities. If a loss of synchronism occurs, it is the responsibility of the Customer to detect the loss of synchronism and immediately trip off the affected loads.

4.4 Load Shedding

Customer load may be shed under certain conditions to prevent system collapse or unacceptable performance after rare major disturbances (Emergency). The Customer may identify the loads (MW) that may be suitable for load shedding purposes to minimize impact to their operations (sheddable load). The requirement of automatic load shedding schemes, the functional requirement and the speed of shedding will be identified as part of the Interconnection Studies. This is in addition to the under frequency load shedding required to meet WECC requirement.

4.5 Remedial Action Schemes

Remedial Action Schemes enable some loads to be continually supplied under system stressed (Emergency) conditions. BC Hydro employs this technique where necessary. BC Hydro will identify any required Remedial Action Schemes during the Interconnection Studies. Remedial Action Schemes operational requirements will be developed and Operating Orders implemented prior to commissioning. Where a RAS is employed, the TVC must actively participate in the Mandatory Reliability Standards requirements (including WECC and NERC requirements). See Appendix G Remedial Action Schemes Requirements for details.

4.6 Customer load Requirements

- (a) Peak Demand

The Customer's Facilities are limited to the Peak Demand (MVA) as identified in the Interconnection Studies.

- (b) Reactive Load Requirements

The load Power Factor requirements are:

- (i) The Power Factor at the Point of Interconnection is a minimum 95% lagging, when the Demand is greater than 75% of the Peak Demand, measured over an interval of five minutes.
- (ii) Leading Power Factor operation is not acceptable unless agreed to by BC Hydro and identified in the Interconnection Studies.

- (iii) Power Factor can be managed through (but not limited to) the following reactive power compensation measures at the Customer plants:
 - A. Automatically or manually switchable shunt VAR device(s)
 - B. Dynamic VAR systems, for example SVC devices or STATCOM
 - C. Synchronous condensers
 - D. Synchronous machine Volt/VAR controls

The Power Factor control scheme must be managed by Customer as well as accepted and coordinated with BC Hydro.

5. STATION REQUIREMENTS

5.1 General

Station circuit breakers, disconnect switches, and all other current carrying equipment connected to the BC Hydro Facilities must be capable of carrying normal and emergency load currents without damage. Only circuit breakers will be acceptable as an interrupting device for protection initiated tripping at the Customer's Facilities.

5.2 Station Insulation Requirements

In general, Customer stations must be protected against lightning, switching surges and temporary overvoltages. To achieve acceptable performance and minimize costs, the Customer shall adopt the "*BC Hydro Insulation Coordination Practices*", attached as Appendix C.

BC Hydro Insulation Coordination Practices for station lightning protection include:

- (a) station shielding using shield wires and/or masts to protect against direct lightning strikes;
- (b) transmission line overhead ground wire shielding for approximately one km outside the station (230 kV and above);
- (c) Surge arresters and surge capacitance (capacitive voltage transformers) on incoming lines; and
- (d) Dedicated surge arresters on major equipment with insulation systems that are subject to damage, such as transformers, reactors and gas-insulated substations.

The line terminal station equipment insulation levels for BC Hydro voltage classes are listed in Table 2.

Table 2: BC Hydro Line Terminal/Station/TX Equipment Ratings (Basic Insulation Level and Switching Insulation Level)

Voltage Class (line - line kV)	Maximum Rated Voltage	Terminal/Station/TX Equipment		Line/Station Surge Arrestors		Capacitance CCVT (nF minimum)
		Basic Insulation Level (kV)	Switching Insulation Level (kV)	V-rating	IEC-Class	
69	72.5	350/350/350	~290/290/290	72/60	2	10
138	152	650/650/550	~540/540/450	144/120	3	10
230	253	950/950/850	850/850/750	228/192	3	10
287	315	1050/1050/950	950/950/850	240/228	4	10

5.3 Clearances

Energized parts shall be maintained at safe vertical and horizontal clearances that are compliant with Canadian standards and WorkSafeBC requirements.

5.4 Transformer Requirements

The Customer should discuss the specifics of each installation with BC Hydro. BC Hydro will provide information on the expected normal and contingency range for the supply voltage. This will provide the Customer with information for the selection of transformer nominal ratio and required tap range.

Customers are normally required to employ delta connected High Voltage windings that do not contribute zero sequence current into system faults.

Where the Customer's facilities include a Power Generating Facility, refer to the "60 kV to 500kV Technical Interconnection Requirements for Power Generators" (available online at:

<https://www.bchydro.com/content/dam/BCHydro/customer-portal/documents/transmission/tgi/technical-interconnection-requirements-for-power-generators-r14-2014-06.pdf>)

for transformer and system protection requirements.

5.5 Circuit Breaker Requirements

All circuit breakers installed as part of the Customer's Facilities must have:

- (a) An interrupting rating equal to or higher than the fault duty at the specific location determined by BC Hydro.

- (b) An ability to meet the ultimate fault duty for the location, as determined by BC Hydro. If the circuit breaker supplied has a lower interrupting rating, the Customer assumes the responsibility for upgrading when necessary to accommodate changes to the system. The stated interrupting capability must not rely on fault reduction schemes such as intentional time delays in clearing.
- (c) An ability to perform all required switching duties, including but not limited to capacitive current switching, load current switching, transformer switching and for special circumstances out-of-phase opening, independent pole switching (if required).
- (d) An ability to perform all required duties without creating transient overvoltages that could damage equipment of BC Hydro or third-parties.

The maximum rated interrupting times required of circuit breakers connected to the BC Hydro Facilities are listed in Table 3. These times apply to High Voltage entrance circuit breaker whether at the Customer's Facilities and/or the Point of Interconnection.

Table 3: Maximum Circuit Breaker Rated Interrupting Times

Voltage Class	Rated Interrupting Time (Cycles)
230 – 287 kV	3
138 kV	3
69 kV and below	5

5.6 Substation Grounding

The equipment and station must be grounded in accordance with the Canadian Electrical Code (Active). It is recommended that the ground grid be designed based on the ultimate fault duty for the site. If not, the Customer assumes the responsibility for upgrading when necessary to accommodate changes to the system. If the Customer has designed the ground grid based on a fault current less than the ultimate fault duty specified by BC Hydro it is the Customer's responsibility to contact BC Hydro periodically to obtain updated the fault level values.

5.7 Standby Generation

Customers with Standby Generation shall have no parallel connection to the BC Hydro Facilities at any time. Thus, applied transfer schemes must be "break" before "make" i.e. the Customer must be disconnected from the BC Hydro Facilities before its local standby generators can connect to Customer loads and operate in an islanded mode.

Special considerations for this type of installation are a suitable CSA approved (or equivalent certification, as deemed acceptable by BC Hydro) mechanical/electrical interlock scheme to prevent the customer from operating in parallel with the BC Hydro Facilities and from energizing the de-energized Facilities.

Permanent Customer-owned standby power supply generators must be equipped with CSA approved transfer switches or CSA approved key interlock switches designed to ensure that the generators cannot feed into the BC Hydro Facilities.

Scheduling is required for planned power system source outages. The Customer will advise BC Hydro if temporary portable generation or an alternative power supply will be used during the outage. If the Customer's electrical configuration will be changed during the outage, the Customer will be considered to be a "hazardous" infeed and boundary isolation procedures as identified in a jointly signed Operating Order will be used.

6. TRANSMISSION LINE REQUIREMENTS

6.1 Transmission Line Insulation and Grounding Requirements

The Transmission Line lightning insulation and ground resistance requirements for BC Hydro voltage classes are listed in Table 4 below. Lines constructed for future operation at a higher system voltage merit special attention to these insulation coordination issues.

Table 4: BC Hydro Unshielded Transmission Line Lightning Insulation and grounding Levels

Voltage Class (line to line kV)	Standard Lightning Critical Flashover (crest kV)	Minimum Shield wire length outside of Stations	Shielded Section Structure Maximum Ground resistance	Unshielded Section Structure Maximum Ground resistance
69	327	0		50 ohms
138	572	0		75 ohms
230	981	1.0 km	10 ohms	100 ohms
287	1226	1.0 km	10 ohms	100 ohms

6.2 Transmission Line Design Requirements

Transmission Line design requirements apply to foundations, structures, hardware, conductors, overhead design, electrical effects, Right of Way, etc.. The specific requirements will be a function of the application. In all cases the Customer shall identify the Registered Professional Engineer of Record responsible for the design. Two ownership options are available:

(a) Transmission Lines to be transferred to BC Hydro

Where the Transmission Line will be transferred to BC Hydro, the transmission line shall be designed and constructed to a standard acceptable to BC Hydro as per BC Hydro Engineering “41” Series Transmission Engineering Technical Standards, Procedures and Guidelines; project specific Transmission Line requirements; and as defined in the “Transmission Line Asset Transfer Requirements Design and Construction Guide”.

(b) Transmission lines not transferred to BC Hydro

Transmission Lines must comply with Good Utility Practice to ensure satisfactory operation and to avoid adverse impacts on the safety and security of the BC Hydro Facilities. As a minimum requirement the design must meet the latest version of Canadian Standards Association standard CAN/CSA C22.3 No.1-10 Overhead System

Where the Transmission Line is a tap connection (69 or 138kV) to the BC Hydro System, the Customer is encouraged to design their Transmission Line to meet or exceed BC Hydro reliability related line performance requirements which include, but are not limited to the following design requirements:

- (i) Electrical clearance requirements are per BC Hydro Engineering “41” Series Transmission Engineering Technical Standards, Procedures and Guidelines;
- (ii) Right of way width and clearing are according to BC Hydro standards (for greater detail, see the “*Transmission Line Asset Transfer Requirements Design and Construction Guide*”).
- (iii) Hazard Assessment outcomes are implemented

7. PROTECTION REQUIREMENTS

7.1 Internal Fault Protection

The Customer’s Facilities’ protection system must have adequate sensitivity to detect and clear all electrical faults in the Customer’s Facilities, and must coordinate with other BC Hydro protection systems, for the present and future (ultimate) fault levels. This protection is generally referred to as “Entrance Protection”. Coordination is defined as either:

- (a) Fully selective clearing, in which the Customer’s Facilities’ protection clears all faults in the Customer’s Facilities before other relays within the BC Hydro Facilities initiate tripping for such faults; or

- (b) Simultaneous clearing, in which the Customer's Facilities' protection clears all faults in the Customer's Facilities simultaneously with the clearing of such faults by BC Hydro Facilities protection.

Fully selective clearing is normally required by BC Hydro for the Customer's Facilities. However, BC Hydro may require simultaneous clearing in certain cases to meet the protection requirements of the BC Hydro Facilities.

7.2 Equipment Rating

The Customer's equipment must be rated to carry, detect and interrupt the present and future fault levels at the Customer's Facilities. To do this, the Customer's station and transmission equipment facilities, including but not limited to all current transformers, potential transformers, secondary cabling, direct current (DC) system/battery charger, switchboard wiring and protective relays, must be designed for the ultimate fault duty.

7.3 Unbalance and Undervoltage

The Customer's equipment may be subjected to negative sequence current due to unbalances on the BC Hydro Facilities. BC Hydro recommends the provision of negative sequence (unbalance) protection (device 46) to protect rotating equipment from excessive and potentially damaging negative sequence current arising from voltage unbalance.

Relays must be based on microprocessor technology and have a dropout time of two cycles or less. The Customer shall coordinate their settings with BC Hydro requirements.

Undervoltage conditions may occur during abnormal operating situations on the BC Hydro Facilities. The Customer is encouraged to use timed undervoltage-tripping (device 27) to protect their equipment.

7.4 Entrance Protection

The Customer's Facilities' entrance circuit breaker must be included in the entrance protection zone. The relays must connect to current transformers on the BC Hydro Facilities side of the circuit breaker, as shown in Figure 4.

Figure 4 illustrates the preferred method of protection, transformer differential protection, with current transformer connections to the transmission side of the entrance circuit breaker.

Figure 4: Generic Entrance Protection One-Line Diagram

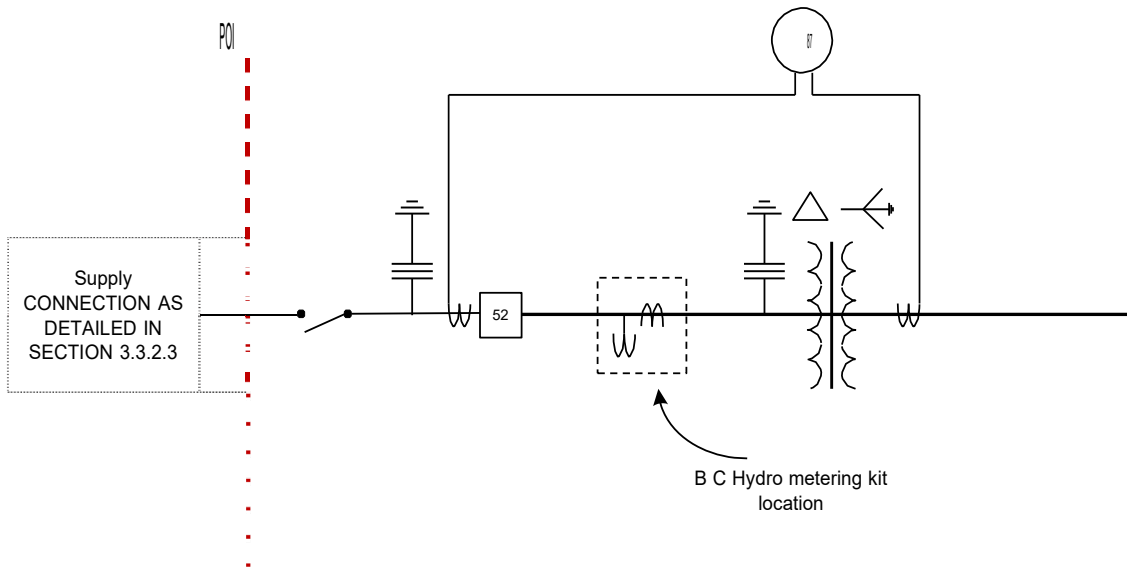

As shown in Figure 4, all BC Hydro's revenue metering equipment must be included in the entrance protection zone or in the Customer's Facilities' internal protection zones. No revenue metering equipment will be located on the BC Hydro Facilities side of the entrance protection zone, unless by special arrangement with BC Hydro.

Figure 5 describes an additional protection example, again emphasizing the application of closed zone protection extending to current transformers on the transmission side of the entrance circuit breaker.

Figure 5: Entrance Protection Example

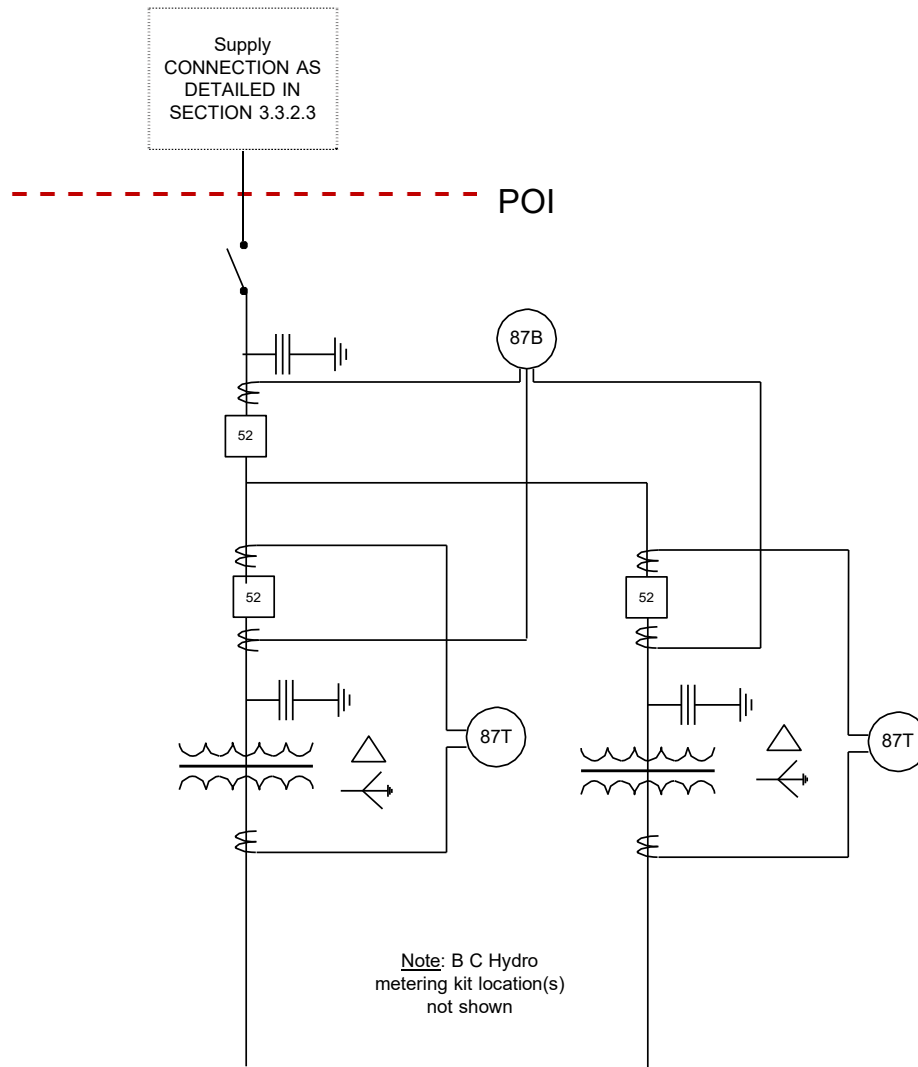

7.5 Transmission Line Protection Requirements

If the Customer has on-site generation that is connected in parallel with BC Hydro, even for momentary conditions, there will be requirements for transmission line protection at the Customer's Facilities. For details, refer to the "60 kV to 500kV Technical Interconnection Requirements for Power Generators", available online at:

<https://www.bchydro.com/content/dam/BCHydro/customer-portal/documents/transmission/tgi/technical-interconnection-requirements-for-power-generators-r14-2014-06.pdf>

7.6 Under Frequency Load Shedding Protection

On all Customer's Facilities installations with a Peak Demand of 5 MVA or higher under frequency load



Power smart

shedding is required. If, subsequent to the initial installation, the Peak Demand reaches or exceeds 5

Technical Interconnection Requirements for Transmission
Voltage Customers for Service at 60,000 to 287,000 Volts

MVA, under frequency relaying must then be applied. The under frequency relay must be of the solid state type. Refer to the WECC Coordinated Off-Nominal Under frequency Load Shedding and Restoration Plan (active) referenced in Section 13.4(a). The under frequency relay must be equipped with a short internal time delay to override Voltage Transients and be capable of being set between 58 and 59.5 cycles. Its setting will be specified by BC Hydro.

The total tripping time of the load shedding scheme (under frequency relay operate time + auxiliary relay operate time + circuit breaker operate time) must be less than or equal to 14 cycles.

The under frequency relay usually trips the Customer's entrance circuit breaker; however, at the Customer's request and on receipt of the necessary information, BC Hydro may permit emergency load retention of approximately 10 percent of normal load, or 2 MW, whichever is lesser.

A staged load shedding scheme may be acceptable to BC Hydro. Customers may indicate the MW load in each block to be shed and an order of preference with respect to shedding. In any case, the frequency set point for the shedding of each block will be established by BC Hydro.

Any revisions to an existing Customer installation will cause the Customer's existing under frequency load shedding scheme to be reviewed. If required by BC Hydro, the Customer will change the scheme to the updated operating requirements.

7.7 Batteries/Chargers/DC Supplies

Batteries are suitable for station applications, if they have a long life when on float charge with no load cycling. In general, this requires the use of lead calcium batteries.

The Customer must ensure that the continuous direct current (DC) supply voltage rating of any relay or its associated power supply is not exceeded due to sustained overvoltages on the DC supply bus. Common causes of high, sustained overvoltages are:

- (a) Battery chargers at their equalize setting;
- (b) Battery chargers connected to the DC supply bus without the station batteries; and
- (c) Battery chargers set in the constant current charging mode

If there is any possibility that the DC rating of a relay will be exceeded, a passive voltage regulator of suitable rating shall be applied to each relay to limit the DC voltage to within that relay's DC rating.

Dual station batteries may be required for power protection and control equipment for the Customer's Facilities connecting to the BC Hydro Facilities at 230 or 287 kV if such connections are permitted. BC Hydro will determine the requirement of dual station batteries during the Interconnection Studies.

The DC supply must:

- (a) Supply power circuit breaker control circuits from dedicated and independently protected DC circuits;
- (b) Supply those physically separated protection systems that are intended to back each other up from dedicated and independently protected DC circuits;

- (c) Provide one undervoltage relay, with time delay, to provide an alarm for battery charger failure or loss of alternating current (AC) supply; and
- (d) Provide one undervoltage relay with adjustable setting capability in a scheme that:
 - (i) Operates at least 5 volts direct current (VDC) above the minimum acceptable voltage to operate the circuit breaker and associated protection and control circuitry
 - (ii) Operates to shut down the load and open the High Voltage circuit breaker to disconnect the Customer's Facilities from the BC Hydro Facilities, and
 - (iii) Has delayed trip initiation, not to exceed one minute, to override temporary Voltage Dips.

8. TELECOMMUNICATIONS FACILITY REQUIREMENTS

8.1 General

Control and telecommunications facilities, including those for protective relaying, Supervisory Control and Data Acquisition (SCADA) and Remedial Action Schemes, may be required at the Customer's Facilities and within the BC Hydro Facilities for safe and efficient operation of the power system and for the safety of personnel. This may include the upgrade of existing transmission and interconnection facilities.

All facilities and equipment defined in sections 8.2, 8.3 and 8.4 require BC Hydro approval (by an authorized BC Hydro telecom professional engineer) to ensure that applicable standards and required functionality, reliability, and availability of spares are met. In some cases, specific equipment may be required to ensure compatibility with existing equipment such as supervisory control and data acquisition and other data monitoring systems.

BC Hydro may modify its control and telecommunications requirements when detailed Customer equipment information becomes available or changes. The Customer should follow BC Hydro telecommunications specifications and drawing templates for consistency, interoperability, and maintainability. All costs to design, procure, install, maintain and support communication access are the responsibility of the Customer.

Telecommunications facilities may be required for any of the following functions:

- (a) Protection;
- (b) Remedial Action Schemes;
- (c) Supervisory control and data acquisition / telemetry;
- (d) Revenue metering (BC Hydro responsibility); and
- (e) Transmission Line maintenance.

8.2 Telecommunications Media

Telecommunications media alternatives for the Customer's Facilities includes, but is not limited to, dedicated or leased metallic wire line circuits, microwave radio, fibre optics, UHF/VHF radio and satellite. When two-way telecommunications media is required, full-duplex (4-wire or equivalent) circuits will generally be used (except for standard voice telephone circuits on wire line, where 2-wire circuits are used).

Whenever metallic pairs are used, the Customer shall provide appropriate telecommunications entrance protection as the station ground potential can rise to hazardous levels above remote ground potential during a power system fault. Telecommunications entrance protection provides safety to personnel, prevents damage to equipment, and allows continuous use of the telecommunications media and the attached equipment during and after power system faults. The Customer is responsible for the installation and maintenance of this equipment and the Customer shall ensure it meets the public carrier and BC Hydro safety and protection requirements.

In cases where the connection is a tap into a circuit that has power line carrier operating on it, a wave-trap is required at the tap point on phase/s of the tap, which could otherwise attenuate the existing carrier signal on the BC Hydro Facilities. In some cases, specialized carrier bypass facilities will be required.

8.3 Telecommunications System for Operating Functions

During Interconnection Studies, BC Hydro will specify the type of equipment required, the interface points and other characteristics required. Facilities which may be required initially or in the future at the Customer's Facilities for communicating with the Control Centres for real-time operation of the power system, include:

- (a) Digital and/or analog telemetry equipment, (including data telecommunications for access to Power Parameter Information System equipment as required);
- (b) Status/alarm reporting equipment;
- (c) Protection;
- (d) Equipment for load shedding or other Remedial Action Scheme actions;
- (e) Voice telecommunications for operating;
- (f) Telecommunications media with required redundancy for the above; and
- (g) Suitable battery and charger systems for the above.

The first two items above are often combined in one or more supervisory control and data acquisition remote terminal units.

In some cases, a single analog business telephone dial-up line may be used to interrogate the main revenue meter, backup revenue meter, and the Power Parameter Information System equipment. This is achieved by sharing a common telephone line using a balanced telephone line-sharing device.

In order to ensure compatibility of design and operation, BC Hydro will provide technical requirements to the Customer for the telecommunications equipment at the Customer's Facilities needed to transmit data from the Customer's Facilities to BC Hydro during the Interconnection Studies.

BC Hydro will not provide High Voltage telecommunication entrance protection equipment.

8.4 Telecommunications System for Teleprotection Functions

Telecommunications assisted protection facilities may be required for power system protection functions at the Customer's Facilities and between locations affected by the Customer's Facilities' connection. BC Hydro will specify the type of equipment required, the interface points and other characteristics required in the Interconnection Studies. The required facilities may include:

- (a) Specialized high-speed teleprotection signals for transmission line protection;
- (b) Telecommunications media for the protection facilities, and for remote access to electronic relays; and
- (c) Battery and charger system, the parameters and size of which will be determined on a case by case basis. Some systems may be specified as 24V floating or 48V positive ground. The battery reserve will typically be eight hours for sites with easy access, or 24 hours or more for sites without easy access.

In order to ensure compatibility of design and operation, BC Hydro will provide technical requirements to the Customer for the telecommunications equipment at the Customer's Facilities needed to transmit and receive teleprotection signals between the Customer's Facilities and BC Hydro.

BC Hydro will not provide High Voltage telecommunication entrance protection equipment.

9. SYSTEM OPERATING REQUIREMENTS

9.1 Normal and Emergency Operations

The Customer shall provide contact information for normal and emergency operations at all times. Communications between the Customer and BC Hydro will be specified in an Operating Order.

9.2 Telemetry and Telecommunications

BC Hydro may require telemetry equipment for readings such as entrance breaker status, MW, MVAR, Amps and kV. Some or all of this data may need to be supplied continuously or via periodic dial-up reporting to the Control Centres. The specific requirements will depend on the size of the load, location, strength of the BC Hydro Facilities at the Point of Interconnection, generation in the area, and other factors. Examples of telemetry information guidelines are shown in Table 4 below; however, the requirements may be increased by BC Hydro if deemed to have safety or significant operational impacts.

Table 4: Telemetry Data and Requirements for Loads

Data	Telecommunications Requirements
<ul style="list-style-type: none"> • Plant level: MW, MVAR, kV, MW.h (hourly), interconnection connection status, • Line telemetry at Point of Interconnection: kV, MW, MVAR 	<ul style="list-style-type: none"> • Real-time report by exception using a remote terminal unit with DNP 3.0 protocol reporting to a data concentration point. • Single dedicated (always on) telecommunications link, i.e. Telus lease, fibre optic, microwave, etc., provided overall polling interval for all data is less than or equal to 2 seconds, or • Stationary Satellite Broadband Link, provided overall polling interval for all data is less than or equal to 4 seconds.

The Customer will adhere to the supervisory control and data acquisition design procedure detailed in reference document BC Hydro Engineering Standard ES45-P0210, as appropriate.

10. COMMISSIONING REQUIREMENTS

10.1 General

The Customer is responsible for the inspection, testing, and calibration of its equipment, up to the Point of Interconnection, consistent with the Facilities Agreement and providing the validated load model and data to BC Hydro.

10.2 Certification of the Customer's Facilities

Prior to commissioning, BC Hydro requires a declaration from a member of the Engineers and Geoscientists British Columbia, or a holder of a license issued by that Association, stating that the Customer's Facilities has been designed, constructed and tested in accordance with:

- (a) Technical interconnection requirements stated in this document;
- (b) The project specific requirements as stated by BC Hydro in the Facilities Agreement;
- (c) Good Utility Practice

BC Hydro requirements for the commissioning of the Customer's Facilities:

- (a) Performance of all commissioning is by competent personnel.
- (b) Compliance with the various declarations of compatibility and commission notice to energize, as required and defined in BC Hydro reference document "*Operating Order 1T-35, Commissioning Procedures for Generation, Stations and Transmission*"

Projects” prior to energizing, loading, and operating. These requirements refer to key aspects where BC Hydro must be confident of the correct operation, settings, calibration and/or installation of equipment. Inspection and testing shall confirm the compatibility of the Customer’s equipment and controls with BC Hydro Facilities where applicable.

- (c) Assignment of a BC Hydro Field Coordinator to the installation in order to assure compatibility as defined in BC Hydro’s OO 1T-35.

10.3 Protection Equipment

Commissioning of protection equipment must include, but is not limited to, the following:

- (a) Ratio, phase and polarity testing of current transformers and potential transformers;
- (b) Calibration checks of each protective relay by injecting the appropriate AC quantities;
- (c) Functional testing of the protective relays to circuit breakers and telecommunications equipment. Testing must include minimum operating point verification for relays;
- (d) Functional and timing testing of Remedial Action Scheme facilities, such as load shedding facilities. RAS commissioning shall comply with Performance verification requirements contained in Appendix G - Remedial Action Scheme Requirements; and
- (e) Load tests of protective relays immediately after initial energization and bus phasing.

BC Hydro will determine and/or review the settings applied to selected relays.

This may involve BC Hydro’s verifying the calibration of the relays by electrical testing and testing of associated circuits and equipment, including tripping the circuit breaker. It may also include on-load checks of the relays following energization of the installation. The settings applied to the relays will be determined or approved by BC Hydro. BC Hydro reserves the right to require Customer to provide documentation of inspection and testing of the protection equipment at any time and to request Customer perform any necessary maintenance.

10.4 Under Frequency Load Shedding

BC Hydro reserves the right to set and calibration test the under frequency relay and test its tripping to the circuit breakers prior to energization of the Customer’s Facilities. BC Hydro also reserves the right to require Customer to provide documentation of inspection and testing of the under frequency load shedding at any time. If requested by BC Hydro, the Customer shall perform any maintenance the testing shows to be necessary.

10.5 Telecommunications Equipment

Functional end-to-end testing of telemetry, teleprotection, alarms, RAS and related equipment is required involving both parties.

10.6 Operating, Measurement and Control Systems Commissioning Requirements

BC Hydro requires testing be conducted on the control and measurement systems, such as testing to confirm the ratio, phase and polarity of non-protection instrument transformers.

BC Hydro may require that a BC Hydro representative witness the commissioning of the Power Parameter Information System. Commissioning includes downloading and testing the device configuration, checking instrument transformer connections, testing UPS function, and confirming dial-up connection and downloading of data.

10.7 Transmission Line

Prior to receiving approval from BC Hydro for connection to the BC Hydro Facilities, the Transmission Line must meet the following requirements:

- (a) Approval by the Electrical Inspector or the authority having jurisdiction;
- (b) Assurance by the named Registered Professional of Record that the constructed transmission line complies with the design;
- (c) Test reports submitted to BC Hydro:
 - (i) T/L structure ground resistance for applicable structures;
 - (ii) Phasing check;

11. MAINTENANCE REQUIREMENTS

11.1 General

The Customer has full responsibility for the maintenance of its equipment, up to the Point of Interconnection, consistent with the Facilities Agreement.

The Customer shall maintain equipment used to control and protect the Customer's Facilities and perform vegetation management all in accordance with Good Utility Practice and applicable reliability standards to ensure that the reliability of the BC Hydro Facilities is not adversely affected. Such maintenance work must be completed by competent personnel.

BC Hydro reserves the right to request Customer to inspect and test their equipment where there is concern that the Customer's Facilities are impacting BC Hydro Facilities.

11.2 Scheduled Outages Requirements

The Control Centres shall coordinate planned outages for maintenance and/or modification on BC Hydro Facilities with the Customer. Customer's Facilities planned outages should not impair the safe and reliable operation of the BC Hydro Facilities.

11.3 Preventive Maintenance Requirements

The Customer is encouraged to have a preventive maintenance program for transmission lines, rights of way clearing and stations, protection and telecommunications equipment. Maintenance will be based on time or on other factors, including performance levels or reliability, and follow any applicable manufacturers' recommendations and/or Good Utility Practice for preventive maintenance.

11.4 Protection and Telecommunications Equipment

Periodic maintenance of protection and telecommunications equipment will include, but will not be limited to, the calibration and functional testing of all protective relays, the associated telecommunications equipment, and the trip testing of the corresponding circuit breakers.

The Customer is responsible for maintenance of the protection and telecommunications equipment and shall keep records thereof to be available to BC Hydro on request. The Customer shall also keep current as-built drawings. It is recommended that this maintenance include calibration testing of the relay and trip testing to the circuit breaker at intervals consistent with the manufacturers' recommendation.

The interval between tests for protective relays and telecommunications equipment shall be in accordance with applicable WECC requirements and Industry Canada regulations.

Customer's Facilities must be available to BC Hydro for testing to provide isolation from current transformers, potential transformers and trip buses and to allow AC injection tests.

11.5 Reliability Requirements

BC Hydro and the Customer shall comply with the applicable reliability standards approved by the British Columbia Utilities Commission for application in British Columbia in addition to any applicable criteria, requirements, policies or guidelines of WECC Reliability that may apply in the western interconnection. TVC owned RAS facilities must meet Mandatory Reliability Standards requirements (including WECC and NERC requirements).

12. OTHER REQUIREMENTS

Other operating and technical requirements will be determined by Interconnection Studies and in negotiations or consultations between the Customer and BC Hydro when the need arises.

13. REFERENCES

The following list of standards is provided for reference only. It is the responsibility of the Customers to comply with all applicable standards.

13.1 BC Hydro

- (a) BC Hydro's Requirements for Complex Revenue Metering
- (b) BC Hydro Insulation Coordination Practices
- (c) BC Hydro Harmonics Control Requirements

- (d) BC Hydro Voltage Flicker Practices
- (e) BC Hydro Engineering “41” Series Transmission Engineering Technical Standards, Procedures and Guidelines
- (f) BC Hydro Standards for ROW Clearing and Clearance
- (g) Vegetation Standard VS 03.2 R2 Transmission Clearance Width
- (h) Vegetation Standard VS 03.10 R4 Transmission Minimum Vegetation Clearance Distance
- (i) BC Hydro Engineering Standard ES45-P0210 Supervisory Control and Data Acquisition Design Procedure
- (j) BC Hydro Operating Order 1T-35 Commissioning Procedures for Generators, Stations and Transmission Projects

13.2 Canadian Standards Association

- (a) CSA C22.1, C22.2 and C22.3 – Canadian Electric Code Parts I, II & III.
- (b) CSA C57-98 (Reaffirmed 2002) Electric Power Connectors for use in Overhead Line Conductors
- (c) CSA C83-96(Reaffirmed 2000) Communication and Powerline Hardware
- (d) CAN/CSA-C411.1-M89 (Reaffirmed 2004) AC Suspension Insulators
- (e) CAN/CSA-C411.4-98 (Reaffirmed 2003) Composite Suspension Insulators for Transmission Applications
- (f) CAN/CSA-G12-92 (Reaffirmed 2002) Zinc-coated Steel Wire Strand
- (g) CAN3-C108.3.1-M84 Limits and Measurement Methods of Electromagnetic Noise from AC Power Systems, 0.15 – 30MHz

13.3 Institute of Electrical and Electronics Engineers (IEEE) Standards (www.ieee.org)

- (a) C37.1 - Standard Definition, Specification and Analysis of Systems Used for Supervisory Control, Data Acquisition and Automatic Control
- (b) C37.2 - Standard Electrical Power System Device Function Numbers
- (c) C37.122 - Standard Gas Insulated Substations
- (d) C57.116 - Guide for Transformers Directly Connected to Loads
- (e) C62.92.5 - Guide for the Application of Neutral Grounding in Electrical Utility Systems

- (f) 80 - Guide for Safety in AC Substation Grounding
- (g) 81 - Guide for Measuring Earth Resistivity, Ground Impedance, and Earth Surface Potentials of a Ground System
- (h) C95.6 - 2002 IEEE Standard for Safety Levels with respect to Human Exposure to Electromagnetic Fields 0 to 3 kHz
- (i) 100 - The New IEEE Standard Dictionary of Electrical and Electronics Terms (ANSI)
- (j) 421-1 - Standard Definitions for Excitation Systems for Synchronous Machines
- (k) 421-2 - Guide for the Identification, Testing and Evaluation of the Dynamic Performance of Excitation Control Systems
- (l) 421-4 - Guide for the Preparation of Excitation System Specifications
- (m) 519 - Recommended Practices and Requirements for Harmonic Control in Electrical Power Systems
- (n) 525 - Guide for the Design and Installation of Cable Systems in Substations
- (o) 605 - Guide for Design of Substation Rigid-Bus Structures
- (p) 979 - Guide for Substation Fire Protection
- (q) 1127 - Guide for the Design, Construction and Operation of Electric Power Substations for Community Acceptance and Environmental Compatibility

13.4 WECC Guidelines (WECC website)

- (a) WECC Coordinated Off-Nominal Frequency Load Shedding and Restoration Plan
- (b) WECC Undervoltage Load Shedding Guidelines
- (c) WECC RAS Design Guide
https://www.wecc.biz/Reliability/RWG%20RAS%20Design%20Guide%20_%20Final.pdf
- (d) WECC Procedure and Information Required for RAS Assessment
<https://www.wecc.biz/Administrative/10a%20Procedure%20and%20Information%20Required%20for%20RAS%20Assessment.pdf>
- (e) NERC standard PRC-015-1 Remedial Action Scheme Data and Documentation
- (f) NERC standard PRC-016-1 Remedial Action Scheme Misoperations
- (g) NERC standard PRC-017-1 Remedial Action Scheme Maintenance and Testing

13.5 Others

- (a) ANSI C84.1 – Voltage Ratings for Electric Power Systems and Equipment (60 Hz)
- (b) Note: Ferrous material shall meet Energy Absorption Level 1 per Clause 6.2.4.1
- (c) O15-05 Wood Utility Poles and reinforcing Stubs
- (d) British Columbia Utilities Commission approved mandatory reliability standards
- (e) Glossary of Terms of NERC Reliability Standards.

APPENDIX A

TRANSMISSION INTERCONNECTION INFORMATION REQUEST FORM

BC Hydro  **Transmission Voltage Customer Interconnection Data Form**

Current Date:

Project Name:

TYPE of STUDY REQUESTED

Refer to [BC Hydro's website](#) for a description of **Conceptual Review** and **System Impact Study**.

Conceptual Review

System Impact Study

How to complete this form

1. Please complete this form electronically and email it to Load.Interconnections@bchydro.com or the BC Hydro representative assigned to this project.
2. Do *not* leave sections blank. Use *None*, *Not Applicable* or *N/A* where appropriate. Complete each section with the best available information to date.
3. Use the *Project Information* section below to describe your project and its purpose.
4. If there are *multiple* sites, please use a *separate form* for each location.
5. BC Hydro may request additional information upon review of this form and attachments.

PROJECT INFORMATION

--

CONTACT INFORMATION

Customer Name:	Consultant Name:
Address:	Address:
Phone Number(s):	Phone Number(s):
Email:	Email:

BC hydro  **Transmission Voltage Customer Interconnection Data Form**

LOCATION INFORMATION

Address:

Latitude (deg min sec):

Longitude (deg min sec):

Property Information (Lot#):

Description (closest town, etc.):

Substation Code (if existing site and BC Hydro customer):

Transmission Line Number (if existing site and BC Hydro customer):

INTERCONNECTION INFORMATION (if new site)

1. The System Impact Study cannot be started if this section is left blank.
2. Refer to [the map of BC Hydro's transmission system](#) prior to completing this section.
3. If you need help selecting a Preferred Point of Interconnection, contact the BC Hydro representative assigned to this project.
4. The Point of Interconnection will be confirmed by BC Hydro during the System Impact Study phase. BC Hydro will inform the customer prior to the completion of the study if the Preferred Point of Interconnection, Voltage or Method is not acceptable.
5. Provide the BC Hydro substation name or code, or the transmission line number for the Preferred Point of Interconnection.
6. The Preferred Interconnection Voltage should match the voltage available at the Point of Interconnection. If the voltage does not match, provide an explanation in the Other Comments section.
7. Examples of Preferred Interconnection Method could be tapped connection or dedicated line position.
8. If available, provide a map of the interconnection location in PDF format with this form.

Preferred Point of Interconnection:

Preferred Interconnection Voltage (kV):

Preferred Interconnection Method:

OTHER COMMENTS

BC hydro  **Transmission Voltage Customer
Interconnection Data Form**

LOAD INFORMATION

1. For each project stage, including construction power (if required), provide the **incremental** Connected Load and Coincident Peak Demand increase, estimated Load Factor and Power Factor after completion of the stage.
2. Project stages beyond eight years are not required in this table.
3. If there are no existing stage, transmission construction power requirement or multiple project stages, enter *N/A* in the relevant row(s).
4. Provide only the steady-state load values. Transient and dynamic load values are *not* required in this table.
5. The *minimum* Power Factor must be 95% or higher (when the actual load is 75% or higher of the Peak Load) for the load to be interconnected to the BC Hydro transmission system.
6. Enter the total Connected Load and Coincident Peak Demand, estimated Load Factor and Power Factor after completion of all project stages.

Project Stage	Requested In-Service Date	Connected Load (MW)	Coincident Peak Demand (MW)	Load Factor (%)	Power Factor (%)
Existing					
Construction Power					
Stage 1					
Stage 2					
Stage 3					
Stage 4					
Stage 5					
Total					

OTHER COMMENTS

**Transmission Voltage Customer
Interconnection Data Form****REQUIRED DOCUMENTS**

Please provide any supporting documentation that could help BC Hydro to complete this information request. The attachments should be provided electronically in PDF format along with a completed version of this form. Information provided must be *clearly* legible if printed on 11" x 17" paper.

Conceptual Review Required Documents

1. *If available*, the customer's substation's **AC Electrical One-line diagrams**. These diagrams should show the connections of all substation equipment.

Where there are multiple electrical one-line diagrams, submit an overall one-line diagram which clearly summarizes the plant distribution substations, connected motor and static loads, capacitor banks or other reactive equipment, and any other major equipment.

System Impact Study Required Documents

1. The customer's substation's **AC Electrical One-line diagrams**. These diagrams should show the connections of all substation equipment, *plus* the following:
 - a. Size, configuration and impedance of transmission transformers
 - b. Size and connection voltage of power factor correcting capacitors or other reactive equipment
 - c. Surge arresters information including manufacturer's name, type, rating (kV), MCOV rating (kV) and energy absorption capability
 - d. Where there are multiple electrical one-line diagrams, an overall one-line diagram which clearly summarizes the plant distribution substations, connected motor and static loads, capacitor banks or other reactive equipment, and any other major equipment
2. Also include customer substation **Site Plans** which must show details of the primary electrical installation. The plans should show the location and orientation of the substation relative to the customer's plant and the proposed transmission connection point.

Note: If a Facilities Study is required *after* the completion of the System Impact Study, BC Hydro will require the customer's substation's P&C One-line diagram(s). The diagram should contain, or be accompanied by, the proposed service entrance fuse size or proposed relay settings. BC Hydro may also request additional information as indicated by the findings of the System Impact Study.

LIST of ATTACHED DOCUMENTS

**APPENDIX B
BC HYDRO LOAD DATA AND MODELLING REQUIREMENTS**

Representative Customer's Facilities data is required by BC Hydro to ensure suitable steps are taken to interconnect the Customer's Facilities to the BC Hydro Facilities. The data requirements will be different at the different Interconnection Study stages; refer to the "Transmission Voltage Customer Interconnection Data Form" (the "Request Form") for specific data requirements at different Interconnection Study stages (Conceptual Review, System Impact Study and any other specific study). This document contains requirements and guidance for the submission of this data.

1. SUBMISSION REQUIREMENTS**1.1. Format**

Wherever possible, all documents (drawings, maps, data curves or other material requested within the Request Form) shall be provided in electronic forms.

The preferred format for reports and other documents is Word for Microsoft Office; for data, drawing indexes and the like is Excel for Microsoft Office.

The preferred formats for drawings are (in order of preference): (i) Auto-CAD *.DXF format, (ii) (Bentley Systems) MicroStation*.DGN format, and (iii) Portable Document Format (PDF).

Unless legibility is a problem, all drawings shall be submitted on either 'A'-size (8.5" x 11"; 21.6cm x 27.9cm), or 'B'-size sheets (11" x 17"; 27.9 cm x 43.2 cm).

Upon BC Hydro's request, engineering data, including substation drawing, equipment specification or any other requested engineering information shall be submitted as signed and sealed copy by a Professional Engineer registered in the Province of British Columbia, in format specified in this section.

2. GENERAL INFORMATION AND TECHNICAL DATA FOR LOAD INTERCONNECTION STUDIES**2.1. General Load Information**

In order to help BC Hydro better understand the load interconnection request, perform adequate Facilities studies, and provide reliable electricity supply service to the Customer, adequate Customer's Facilities information and load data is required. The Customer is responsible for providing information that is representative of the Customer's Facilities and validating the information if required.

(a) Load Location and Connection Information

The proposed load interconnection location information shall identify the:

- (i) Proposed Customer industrial plant and or substation (nearest town, latitude and longitude, elevation);
- (ii) Driving directions to the Customer's Facilities location for a site evaluation;
- (iii) Substation name if connecting to an existing BC Hydro substation(s); and

- (iv) Line name by designation if connecting to an existing BC Hydro Transmission Line.

(b) Description of Industrial Process

The Customer shall provide a high level description of the industrial process and load characteristic. Examples could include:

- (i) Variable loads such as excavating electric shovels;
- (ii) Constant loads such as compressor motors;
- (iii) Repetitive load such as arc furnace;
- (iv) Seasonal changes;
- (v) Sensitivity to outage duration; and
- (vi) Recovery and restarting mode.

(c) Service Reliability

Based on the characteristics of industrial process the power supply reliability expectation shall be identified, for example:

- (i) Power supply is required under system normal condition only; the service can be interrupted under forced or scheduled Facilities outage; or
- (ii) Redundant power supply capability is necessary.

(d) Target In-service Date(s)

Realistic in-services dates should be provided for the various stages of plant development, including construction power, first energization power and next stage plant development.

2.2. Electrical Data

The electrical data required will depend upon the type of connection requested.

(a) General Facility Data (Project)

- (i) Peak Demand in the final stage is the critical load value for the Interconnection Study. Intermediate load values are more important for scheduling and project staging.
- (ii) Loads nominated for shedding. These values give the Customer the opportunity to protect critical loads from shedding. The default position is BC Hydro shedding full Customer load.
- (iii) Electric One-Line Diagram shall include equipment ratings, equipment connections, transformer configuration, load configuration, grounding, bus, circuit breaker and disconnect switch arrangements, etc.

(b) Electric Motor Types and Control Data

Electric motors consist of the major part of the industrial load. In general, motor load characteristics and controls may have significant impact for the electric power system performance.

(i) Motors

For individual synchronous or induction motors greater than 1000 hp (0.76 MW), detailed electric parameters and control types are required for load modelling as described in the Request Form.

(ii) Motor Drives

Motor drives information in the Request Form shall include reactive and non-linear loads for AC/DC Converter devices employed with motor operation.

- A. Number of drives and types;
- B. Nominal AC voltage, kV;
- C. Schematic drawing of the drives' main power circuit ;
- D. Control method (PWM, LCI or others) and functional diagrams describing expected performance;
- E. Main protection function settings (those that will impact Customer's Facilities performance):
 - I. Overload,
 - II. Under voltage, over voltage blocking including threshold values; and
 - III. Threshold values for restart/unblocking operation;
- F. Low voltage ride through capability.

(c) Transformer Data

Data shall be provided for each entrance and any major load transformers as described in the Request Form. The proposed method of transformer switching should also be identified in this section.

(d) Shunt Compensation Devices

Equipment data shall be provided for the reactive compensation devices as described in Request Form. In addition to this data the reactive compensation application strategy (including static, dynamic, and filters) should be described as associated to the load variation and possible system conditions.

(e) Transmission Data

If a new Transmission Line or cable is to be included as part of the proposed connection, the Transmission Line data shall be provided in the Request Form.

(f) Line Entrance Equipment

Information on circuit breakers, disconnecting switches, surge arresters, capacitive voltage transformers and fuses are to be included in the Request form.

(g) Additional Models for Complex Load Representations

(i) EMTP/PSCAD Compatible Models

Customer supplied working study models should be compatible with BC Hydro EMTP-RV or PSCAD versions with compiler compatible with BC Hydro versions.

The EMTP models will be used primarily for system and equipment review of:

- A. Resonance/harmonic interactions;
- B. Load-System unbalanced conditions; and
- C. System, system equipment and Customer's Facilities and Customer's Plant transient performances related to TOVs, switching & lightning where realistic representations of non-linear effects such as transformer saturations, surge arresters and non-simultaneous switching operations are important for proper performance evaluations.

Typical Models for Planning (Not Design)

- D. Motor Drives: VFDs, LCI , Cyclo-converters;
- E. Inverter Loads (at non fundamental frequencies); and
- F. Dynamic/Active Filters, if any
 - I. Number of branches
 - II. Tuning frequencies.

(h) Facilities Data Validation

The results of the Interconnection Studies are dependent on the data being representative of Customer's Facilities site conditions. If the Interconnection Studies identify that Customer's Facilities models or data validation will be required, validation shall be accomplished by:

- (i) Supply of type test reports for the equipment installed at the Customer's Facilities;

- (ii) Supply of routine test results for the equipment installed at the Customer's Facilities;
- (iii) Performance of site testing as defined in the Interconnection Studies and executed in the commissioning stage; or
- (iv) A combination of the above.

APPENDIX C
BC HYDRO INSULATION COORDINATION PRACTICES**1. INTRODUCTION**

Insulation coordination is the process of equipment selection in relation to the voltages which can appear on the system for which the equipment is intended and taking into account the service environment and the characteristics of the available protective devices. An acceptable risk of failure is considered when selecting the insulation strength of equipment.

2. VOLTAGE STRESS SOURCES

Voltage stresses, such as lightning or switching surges, and temporary over-voltages may affect equipment duty.

2.1 Lightning (Fast Front) Surges

Lightning is a natural phenomenon that results in fast front voltage surges that are a function of the lightning discharge current and line surge impedance. The line flashover voltage will be the limiting parameter for the surge voltage. More important is the rate of rise of the resultant surge. Surges that occur a long distance from a station can be protected against. Lightning strikes that occur close to the station are a problem due to the high rate the voltage rises.

A line provided with an overhead shield wire system can reduce the probability of occurrence of a lightning strike to the phase conductors. An overhead shield wire system relies on a low tower to ground resistance to prevent a back flashover from the tower to a phase conductor. The native geology and resulting high ground resistivity conditions in British Columbia makes it uneconomic to provide continuous overhead shield wire systems.

BC Hydro lines are typically not shielded from lightning, and the tower footing resistances can be much larger than those normally encountered for shielded lines.

A short length of shield wire at the station entrance with compatible tower footing resistances will provide sufficient reduction in the rate of rise of surge voltage (rise time on the order of 1 μ s) to permit surge protection devices to protect the other station equipment.

All lines that terminate at BC Hydro substations must have station entrance surge protection while those at 230 kV and higher require short lengths of overhead shield wire at the station entrance with compatible tower footing resistances. (See Table C-2 for line shielding requirements for lines entering BC Hydro stations.)

2.2 Switching (Slow Front) Surges

The wave shape for the slow-front or switching surges may vary over a wide range depending on the circuit involved. Typically, the front times range from 20 μ s up to 5 ms.

Switching surges are typically caused by line switching events. Slow front overvoltages may also result from reactive switching of shunt capacitors and reactors, bypassing of series capacitor banks or remote distance lightning strikes.

Switching surges can be controlled by the application of pre-insertion resistors, point on wave switching or special line arrester applications.

Lines and stations rated above 300 kV require special attention to switching surge voltages in their design.

2.3 Temporary Over voltages

A temporary overvoltage is an oscillatory phase-to-earth or phase-to-phase condition that is of relatively long duration and is undamped or only weakly damped. Temporary overvoltage magnitudes are determinable and the effect on insulation is considered in steady-state terms. Temporary over-voltages can last from seconds to minutes, and are not characterized as surges. These over-voltages are present during islanding, faults, loss of load, or long-line situations. All new and existing equipment shall be capable of withstanding these duties. The following causes of temporary overvoltage are typically considered:

- (a) **Earth fault overvoltage** - occurs over a large part of the system. Guidance for the determination of temporary overvoltage amplitudes is given in Annex B of IEC 71-2. The duration of the overvoltage corresponds to the period of the fault (until fault clearing). Within earthed neutral systems it is generally less than 1 s. For resonant earthed neutral systems, with fault clearing, it is generally less than 10 s and systems without earth fault clearing the duration may be several hours.
- (b) **Load rejection** - following disconnection of a load, the voltage can rise at the source side of the operating circuit breaker. The amplitude of the overvoltage depends on the disconnected load and the short-circuit power of the feeding substation. The temporary overvoltages have particularly high amplitudes after full load rejection at generator transformers depending on magnetizing and over-speed conditions. The amplitude of load rejection overvoltages is usually not constant during its duration. Accurate calculations have to consider many parameters, the following typical values of such overvoltages may be considered:
 - (i) **Moderately extended systems** - a full load rejection can give rise to phase-to-earth overvoltages with amplitude usually below 1.2 p.u. The overvoltage duration depends on the operation of voltage-control equipment and may be up to several minutes.
 - (ii) **Extended systems** - after a full load rejection, the phase-to-earth overvoltages may reach 1.6 p.u. or even higher when Ferranti or resonance effects occur. Their duration may be in the order of some seconds.
 - (iii) **Load rejection of generator transformers** - the temporary overvoltages may reach amplitudes up to 1.4 p.u. for turbo generators and up to 1.5 p.u. for hydro generators. The duration is approximately 3 s.
- (c) **Resonance effects** - e.g. when charging long unloaded lines or resonance between systems
- (d) **Voltage rise along long lines** (Ferranti effect)
- (e) **Harmonic overvoltage** - e.g. when switching transformers
- (f) **Back feed through interconnected transformer windings** - e.g. dual transformer station with common secondary bus during fault clearing or single-phase switched three-phase transformer with an unbalanced secondary load.

- (g) **Neutral Shifts in Ungrounded Networks** – Customers are normally required to connect to the BC Hydro Facilities by a delta-grounded wye (Δ -YG) transformer to prevent Customer zero sequence currents from interfering with line protection. For the transmission line network supplying the Customer loads the system grounding is provided only at the BC Hydro station. Therefore, when the normally grounded Customer lines becomes isolated from the BC Hydro station—usually due to a line to ground fault—phase level over-voltages can occur on the unfaulted phases. These over-voltages can affect personnel safety and damage equipment when they are rated for grounded system. This type of over-voltage is commonly described as a neutral shift and can increase the voltage on the un-faulted phases to 1.73 per unit or higher if there is significant line capacitance and backfeeds from small motor load(s) without any drives. At these excessive overvoltages, the equipment insulation withstand duration can be very short. See Table C-1 for typical phase-to-earth overvoltages encountered in power systems.

Table C-1: Typical phase-to-earth overvoltages encountered in power systems.

Sources	Typical p.u. Range (1 p.u.= $\sqrt{2} \times Us/\sqrt{3}$)	Breaker RRRV kV/ μ s
Temporary Overvoltages Single-Line-To-Earth Faults: Effectively Earthed System Unearthed System Load Rejection Ferranti Effect: 200 km line 300 km line Closing of Transformer Terminated Line	1.3 to 1.4 ≥ 1.7 1.2 to 1.5 1.02 1.10 1.2 to 1.8	
Slow-front Overvoltages Line Energization Discharged Line Three-phase reclosing without Preinsertion Resistors Three-phase reclosing with Preinsertion Resistors Three-phase reclosing with arresters (3 sets at 1,5 p.u. Ups) Three-phase reclosing with Breaker Control Closing at zero voltages Single-phase reclosing Fault Initiation: Unfaulted Phase Coupled Circuit Fault Clearing	1.5 to 2.9 3.0 to 3.7 1.6 to 2.2 1.8 to 2,5 1.5 to 1.7 1.5 to 2.0 2.1 1.5 1.7 to 1.9	
Shunt Capacitor Switching Earthed: breaker condition without restrike Unearthed: breaker with restrikes, no surge arrester breaker with restrikes, with surge arrester (NOTE: specific overvoltages are dependent on arrester ratings and installation)	1.7 3.0 ~ 2 to 3a	2.0 4.0 3.0
Circuit Breaker Transient Recovery Voltages (TRV) & Rate-of-Rise-of-Recovery Voltages (RRRV; kV/μs) Normal Circuits TRV crests RRRV Inductive circuits TRV crests RRRV; no TRV capacitors RRRV; with TRV capacitors	1.7 ~ 3.0	
Fast-front Line surges Entering Stations Unshielded Line Shielded lines	4.0 4.0	

3. COORDINATION PRINCIPLES

Relationships between typical overvoltage stress with and without surge arrester protection and insulation strength encountered in power system is illustrated in Figure C-1.

Figure C-1: Voltages and duration example for an efficiently earthed system

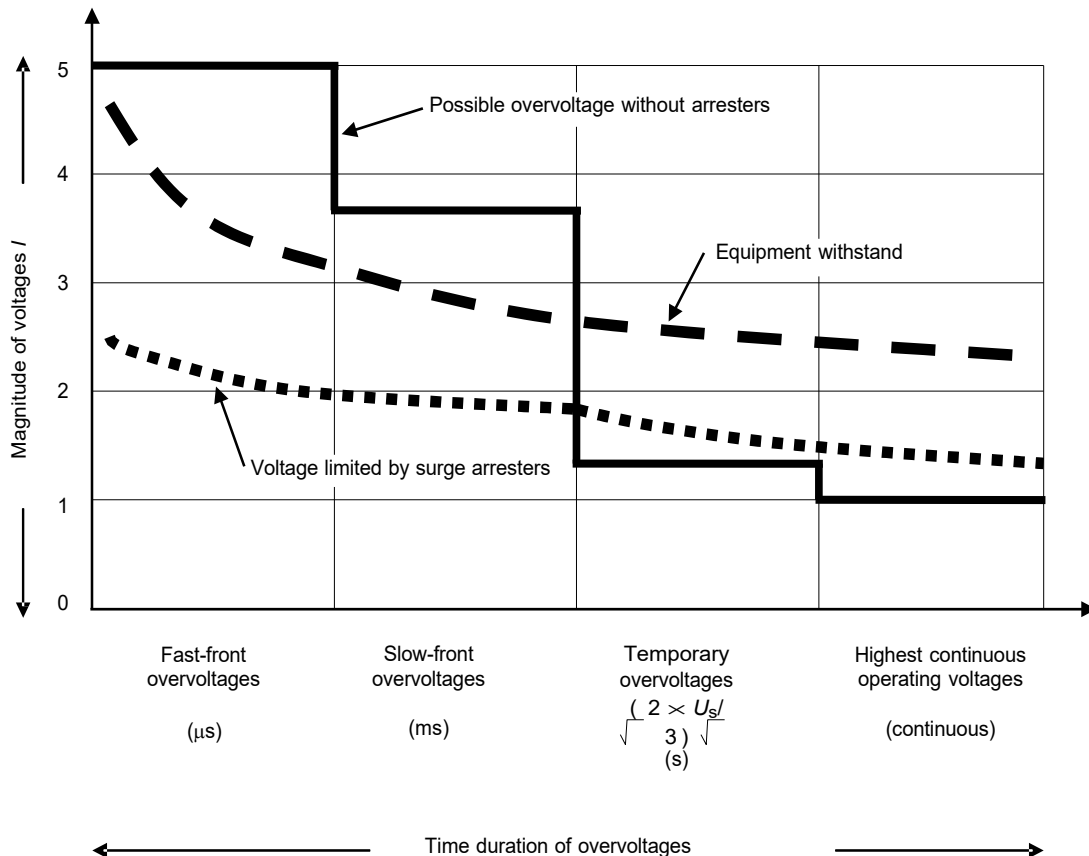

NOTE: $1\text{p.u.} = \sqrt{2} \times U_s / \sqrt{3}$

Insulation coordination is achieved by implementing the following:

- (a) Avoid very fast front surges (i.e. less than $1 \mu\text{s}$ rise times) in stations;
- (b) Applying surge arresters in the station to limit the voltage magnitude;
- (c) Having equipment with appropriate ratings and withstand capability (both line to ground and across open gaps);
- (d) Avoiding excessive temporary overvoltages.

4. BC HYDRO PRACTICES

The BC Hydro Facilities can be characterized as follows:

- (a) The BC Hydro Facilities under normal operating conditions is effectively grounded (with $X_0/X_1 \leq 3.0$ and $R_0/X_1 \leq 1.0$). Some parts of the system can under certain circumstance be temporarily backfed as an ungrounded system
- (b) BC Hydro lines are typically not shielded from lightning, and the tower footing resistances can be much larger than those normally encountered for shielded lines

- (c) For security reasons, most lines have (10s) reclose feature. Extra-High-Voltage (325 kV phase to phase and above) lines have the possibility for high-speed (0.5-1.0s) reclose. Single pole reclosing is applied on some lines 230 kV and above
- (d) Switching surge control is typically applied only at 500kV by way of closing resistors, special application surge arresters and/or controlled switching to limit the surges to 1.7 to 2.0 pu (>98% of the time)

BC Hydro accommodates the anticipated voltage stresses by implementing the following insulation coordination practices:

4.2 Lightning

- (a) All BC Hydro stations are fully shielded to eliminate the possibility of a direct strike.
- (b) Line shielding over short distances (~1 km) from the station are applied on lines operated at 230 kV and above to reduce the incoming surge front rate of rise into the station.
- (c) Minimum line entrance capacitance provided by a Capacitive Voltage Transformer (CVT) or Coupling Capacitor is 10nano farads.
- (d) Since BC Hydro transmission line insulation levels are typically higher than line entrance equipment, surge arresters are applied at the line terminals to limit incoming lightning and/or switching over-voltage surges.
- (e) Surge arresters are installed on all transformers, reactors and other equipment requiring additional protection. As the cost of insulation is usually higher for this equipment surge arresters with lower protective levels are applied.

4.3 Switching (Slow front) Surges

- (a) Application of surge arresters to limit switching surge voltage magnitude.

4.4 Temporary Over Voltages

- (a) Identify potential temporary overvoltage situations in the Interconnection Studies:
 - (i) Temporary overvoltages due to Ferro resonance should not form the basis for the surge arrester selection. The use of a surge arrester as an extra burden to damp out the Ferro resonance is not effective and unproven. The same argument is applicable to linear resonance. There are different modes of Ferro resonance. The sub-harmonic mode Ferro resonance will not generate an overvoltage. However, for the fundamental frequency mode Ferro resonance, a high temporary overvoltage is possible.
 - (ii) A combination of causes such as earth faults and load rejection may result in higher temporary overvoltage values than those from the single events. When such combinations are considered sufficiently probable, the overvoltages for each cause shall be compounded taking into account the actual system configuration and carefully examining the amount of rejected load dependent on the fault and arrester locations.

- (iii) The sequence of causes for temporary overvoltages, e.g. load rejection caused by an earth fault, needs consideration since both overvoltages have comparable severity. In such cases, the amount of rejected load is dependent on the fault location and the arrester location shall be carefully examined.
- (b) Where potential temporary overvoltage situations are present use a higher rated surge arrester. This is to prevent a surge arrester failure, i.e. where a system may become ungrounded during a single phase fault event, a 144 kV rated arrester is used on a 138 kV system as opposed to a 120 kV arrester.
- (c) Implement high speed separation of back feed sources to prevent the ungrounded situation. This requires telecommunication channel between BC Hydro and the Customer's Facilities.
- (d) Neutral shift - several alternative remedies to avoid neutral shift and its potential problems are possible. The following describes two possible solutions that may be considered by BC Hydro:

- (i) Effectively Grounded System

An effectively grounded system is defined as a system with $X0/X1 \leq 3.0$ and $R0/X1 \leq 1.0$. An effectively grounded system will minimize the risk of damage to surge arresters and other connected equipment. Utilizing appropriate transformer connections on the high-voltage side will make the system effectively grounded. Though HV transformer connections are preferably delta, in cases where there are issues as described above, different transformer connections may be prescribed.

Transformer connections typically used to obtain an effective ground on the high-voltage side of a transformer include the following:

- A. Installation of a grounding transformer on the high-voltage side.
 - B. A transformer with the transmission side connected in a YG configuration and low-voltage side in a closed Δ .
 - C. A three winding transformer with a closed Δ tertiary winding and both the primary and secondary sides connected YG.
- (ii) High Speed Separation of Back-feed Source(s)
 - (iii) Other solutions may be effective which do not involve the addition or replacement of major equipment. This includes the application of telecommunications channels from BC Hydro to the Customer which ensures the customer is tripped off before the BC Hydro terminal has opened.

Whatever solution or combinations of solutions is chosen will be determined by BC Hydro at the time of the Interconnection Studies.

- (e) Temporary over-voltages can last from seconds to minutes, and are not characterized as surges. These over-voltages are present during islanding, faults, loss of load, or long-line situations. All new and existing equipment shall be capable of withstanding these duties.

- 4.5 In all cases, equipment is purchased with voltage rating that coordinates with the surge arresters applied (See Table C-3).
- 4.6 Longitudinal insulation coordination requires that for isolating equipment, a flashover does not occur across an open gap. Where flashover does occur it shall take place as a line to ground flashover. For disconnecting switches and circuit breakers rated at 230 kV and above, BC Hydro requires confirmation of longitudinal insulation coordination (i.e. across the open gap) using a “Bias test”. A Bias Test applies a switching surge on one terminal and an AC waveform on the other with the timing of the switching surge to occur at the peak of the opposite polarity. Longitudinal coordination is normally only required where terminals connected to the same phase are separated into two independently energized parts.
- 4.7 Some BC Hydro system lines are insulated for future use at a higher system voltage than present operation. For example, a 230 kV line may be built to 500 kV standards. Connections to these lines shall be designed and insulated with the ultimate usage taken into account. Some equipment in the station such as transformers, surge arresters and circuit breakers may be rated for the actual operating voltage; however, special attention shall be given to insulation coordination in consideration of the higher surges that the line can be delivered to the station.

Table C-2: Facilities Characteristics

Voltage (line to line kV)	Class	Lightning Flashover (CFO) (crest kV)	Critical	Shielding Station Minimum Number of Spans	@ Number	Shielded Section Tower Footing R max (Low Frequency)
69		327		0		
138		572		0		
230		981		~3 (~1.0 km)		10 ohms
287		1226		~3 (~1.0 km)		10 ohms
360				~1.5 km		15 ohms
500				~1.5km		20 ohms

Table C-3: Station Equipment ratings

Voltage Class (line - line kV)	Max. Voltage	Terminal/Station/TX Equipment		Line/Station Surge Arrestors		Capacitance CCVT (nF min)
	kV	Basic Insulation Level	Switching Insulation Level	V-rating (kV)	IEC- Class	
69	72.5	350/350/350	~290/290/290	60 grounded	2	10
				72 ungrounded		
138	152	650/550/550	~540/450/450	120 grounded	3	10
				144 ungrounded		
230	253	950/950/850	850/850/750	192 grounded	3	10
				228 ungrounded		
287	315	1050/1050/950	950/950/850	228 grounded	4	10
				240 ungrounded		

Power system equipment is designed to withstand voltage stresses associated with expected operation. Adding or connecting new facilities can change equipment duty, and may require existing equipment to be replaced or new switchgear, telecommunications, shielding, grounding and/or surge protection be added to control voltage stress to acceptable levels.

Interconnection Studies shall include the evaluation of the impact on equipment insulation coordination. BC Hydro may identify additional requirements to maintain an acceptable level of BC Hydro Facilities availability, reliability, equipment insulation margins and safety.

APPENDIX D
BC HYDRO HARMONICS CONTROL REQUIREMENTS

1. INTRODUCTION
1.1 Scope

This document provides guidance and requirements on the limits of harmonic distortion that may be introduced into the Facilities by customers taking supply at voltages from 69kV to 287kV. The purpose is to establish an equitable procedure for the control of harmonic distortions to be shared between BC Hydro and its customers. This document also defines the responsibilities of BC Hydro in providing and administering interconnections for harmonic-producing customers.

1.2 Definitions

- (a) *Individual harmonic distortion (IHD)*: The individual harmonic distortion value of a waveform is defined as the RMS value of a harmonic component expressed as a percentage of the RMS value of the fundamental frequency component. In the case of harmonic voltage distortion, the nominal operating voltage shall be used as the RMS value of the fundamental frequency component. In the case of harmonic current distortion, the maximum fundamental frequency load current under normal operating conditions shall be used as the RMS value of the fundamental frequency component.
- (b) *Total harmonic distortion (THD)*: The total harmonic distortion value of a waveform is the root-sum-square of individual harmonic distortion values, as defined in Equations (1.1) and (1.2). BC Hydro requires that up to fortieth (40) harmonics shall be included in the THD calculation:

$$\text{THD(voltage)} = \frac{\sqrt{V_2^2 + V_3^2 + \dots + V_{40}^2}}{V(\text{normal})} \quad (1.1)$$

$$\text{THD(current)} = \frac{\sqrt{I_2^2 + I_3^2 + \dots + I_{40}^2}}{I(\text{maximum})} \quad (1.2)$$

- (c) *Total harmonic current*: Total harmonic current of a current waveform is defined as the root-sum-square of the RMS magnitudes of individual harmonic currents:

$$\text{Total harmonic current} = \sqrt{I_2^2 + I_3^2 + \dots + I_{40}^2} \quad (1.3)$$

- (d) *Residual I*T product*: The residual I*T is the root-sum-square value of the zero sequence RMS harmonic currents multiplied by the TIF weighting factors. The values of TIF weighting factor can be found in reference 1.3(a) or 1.3(f).

- (e) *Noise Metallic (Nm)*: Noise metallic, which is also referred to as telephone circuit noise, is defined as a metallic voltage impressed between tip and ring of a telephone set and measured as a power level across a 600 ohm load. Nm is expressed mathematically as $10 \times \log$ (unit: dBm) of the square of the difference between the tip-to-ground and the ring-to-ground voltages divided by the metallic circuit impedance. The metallic voltage is normally weighted with certain factors at different frequencies. This guideline uses C-message weighted voltage (dBmC) (see reference 1.3(f) below).
- (f) *Noise to Ground (Ng)*: Noise to ground, which is a measurement of the influence of power system currents on a telephone circuit, is the average of tip-to-ground and ring-to-ground voltages measured as a power level across a 600 ohm load. Ng is expressed mathematically as $10 \times \log$ (dBm) of the square of the average voltage divided by the reference impedance of 6001. This guideline uses C-message weighted average voltage (dBmC) (see reference 1.3(f) below).
- (g) *Cable (longitudinal) Balance*: Cable balance, which is a measurement of the susceptibility of a telephone cable, is the difference between noise to ground and noise metallic expressed in dBmC (see reference 1.3(f) below).
- (h) *Background Voltage Harmonics*: Background voltage harmonics are the harmonic voltages that exist at POI when the customer installation is not connected to the supply system or is connected but not drawing load current from the supply system.
- (i) *Total Plant Load*: Total plant load is the contract total plant MVA demand, without subtracting customer's co-generation capacity if any, for normal plant operation.
- (j) *Total Plant Load*: Total plant load is the contract total plant MVA demand, without subtracting customer's co-generation capacity if any, for normal plant operation.
- (k) *Harmonic Loads*: Harmonic loads in a plant are those primary industrial loads that can cause more than 5% of total harmonic distortion in the load currents when supplied with a sinusoidal 60Hz voltage. In most cases, harmonic loads are DC drives, variable frequency AC drives, rectifiers, and possibly uninterruptible power supplies.

1.3 References

This guideline makes reference to the following documents:

- (a) IEEE Std.-519: "IEEE Recommended Practices and Requirements for Harmonic Control in Electric Power Systems", 1992.
- (b) CSA-C22.2 No.0.16-M92: "Measurement of Harmonic Currents", 1992.
- (c) CSA-C22.2 No.3: "Inductive Coordination", 1954 and No.3.1: "Inductive Coordination Handbook", 1974. (This standard is currently under revision.)
- (d) CIGRE JTF 36.05.01/14.03.01 Report: "Connection of Harmonic Producing Installations in High-Voltage Networks with Particular Reference to HVDC", 1991.
- (e) UK Engineering Recommendation G.5/3: "Limits for Harmonics in the United Kingdom Electricity Supply System", 1976.

- (f) CEA&TCEC Joint Report: "Electrical Coordination Guide", 1989.

2. GENERAL PROCEDURE

This guideline deals with harmonic-producing installations in categories, according to the size of an installation and the capacity of its supply system.

Category I (small) installations can be accepted by BC Hydro without performing detailed harmonic analysis in the plant design stage¹.

Category II (large) installations are required to perform and submit for BC Hydro's inspection harmonic study at the plant design stage. The study shall demonstrate that BC Hydro's harmonic design limits are met.

At BC Hydro's sole discretion, certain customers are required to demonstrate, through field measurements, that their installations comply with BC Hydro's harmonic measurement limits during the plant commissioning stage and/or normal operation.

2.1 Criteria for Category I Installation.¹

A customer installation is considered as category I if

- (a) The ratio of total harmonic load MVA in the plant with respect to the total plant load MVA, in percentage, is below the curves shown Figure B.1. The total harmonic load MVA shall be estimated according to the following formula:

$$\begin{aligned}
 \text{Total harmonic load MVA} = & \\
 & 0.85 \times (\text{total MVA of harmonic loads configured in more than 6 pulses}) + 1.00 \times (\text{total MVA of other harmonic loads in the plant})
 \end{aligned}
 \tag{2.1}$$

- (b) The customer's capacitors should not cause harmonic resonances, namely the following condition is satisfied for every harmonic number h:

$$|h_{\text{resonance}} - h| > \begin{cases} 0.35 & h-5,7,11,13,17,\dots \\ 0.10 & h-2,4,6,8,10,\dots \\ 0.15 & h-3,9,15,21,27,\dots \end{cases}
 \tag{2.2}$$

In the above equation, $h_{\text{resonance}}$ is the (parallel) resonance frequency in multiples of 60Hz. This frequency is normally obtained by a frequency scan analysis of the plant. This equation needs to be checked only for the two harmonics adjacent to $h_{\text{resonance}}$. If there is only one capacitor location in the plant, the frequency may be estimated according to Equation (2.3):

$$h_{\text{resonance}} = \sqrt{\frac{MVA_{\text{sys}}}{MVA_{C,P}}}
 \tag{2.3}$$

where MVA_{sys} is the system fault MVA seen at the capacitor bus. This MVA shall include the contribution of non-harmonic-producing loads such as motors in the plant. MVA_C , is the installed capacitor MVA calculated at normal operating voltage. It shall be noted that both MVA_{y} , and $MVA_{C,P}$

¹ If any category 1 installation causes harmonic problems, BC Hydro is entitled to apply harmonic design and measurement limits to the installation.

may vary with the operating conditions of the supply system and the plant. The limits of Equation (2.3) shall be satisfied for all conditions.

2.2 Criteria for Category II Installation

Any installations not belonging to category I are considered as category II. These installations shall satisfy BC Hydro that the harmonic design and/or measurement limits as specified in Sections 3 and 4 are complied with.

2.3 Engineering Information Required from Customers

Customers in either category shall provide BC Hydro, with the following data:

- (a) Single-line diagram of the installation.
- (b) All non-harmonic-producing industrial loads (for most customers this means the load with demand greater than 760 kW).
- (c) All harmonic producing industrial loads (demand greater than 760 kW for most customers) and their harmonic spectrums.
- (d) Supply transformers and other transformers for primary industrial application purpose. Distribution cables and lines that cannot be neglected for harmonic analysis. Power factor correction capacitors and harmonic filters, if any.
- (e) A harmonic assessment report based on the above information. For category 1 installation, the report shall demonstrate that the installation can be considered as category 1. For category II installation, the report shall demonstrate that the BC Hydro harmonic design and/or measurement limits are satisfied.

2.4 Examples

Example 1

The total plant load is 100MVA

Utility supply is at 287kV

The system fault level at POI is 5000MVA

= > Therefore ratio of system fault MVA to demand MVA is 50 (=5000/100).

Harmonic-producing loads in the plant are as follows:

* 6.0 MVA 12-pulse DC drives

* 5.0 MVA other harmonic loads

* total harmonic load is then 10.1 MVA (=1.00x5.00+0.85x6.00), as per Eq. (2.1) ==> Therefore percentage total harmonic load is 10.1% (=10.1/100)

Conclusion: As per Figure B.1, point (50, 10.1%) falls above the 287kV curve. The installation is a category II type.

Example 2

- The total plant load is 30MVA
- Utility supply is at 69kV
- The system fault level at POI is 1700MVA
- ⇒ Therefore ratio of system fault MVA to demand MVA is 57 (=1700/30).

Harmonic-producing loads in the plant are as follows:

- * 2.0 MVA 12-pulse adjustable speed drives
- * 3.2 MVA other harmonic loads, including a 2MVA 6-pulse DC drive
- * Total harmonic load is then 4.9MVA (=1.00x3.2+0.85x2.0), as per Eq. (2.1)
- ⇒ Therefore percentage total harmonic load is 16.3% (=4.9/30)
- ⇒ As per Figure B.1, point (57, 16.3%) falls below the 69kV curve. The installation passes harmonic chart requirement. Harmonic resonance check is followed.

- The plant capacitor banks, installed in one location, are 1.2MVar
- The fault level at the capacitor bus is 150MVA
- ⇒ Therefore $h_{resonance}$ is 11.18 (=SQRT(150/1.2))

$$|h_{resonance} - h| = 0.18 < 0.35 \text{ for } h=11 \Rightarrow \text{not okay}$$

$$= 0.82 > 0.10 \text{ for } h=12 \Rightarrow \text{okay}$$

Conclusion: Although satisfying the harmonic chart requirement, the plant fails the harmonic resonance check. The installation is a category II type.

Example 3

- The total plant load is 30MVA
- Utility supply is at 69kV
- The system fault level at POI is 1700MVA
- ⇒ Therefore ratio of system fault MVA to demand MVA is 57 (=1700/30).

- Harmonic-producing loads in the plant are as follows:

- * 2.0 MVA 12-pulse adjustable speed drives
- * 3.2 MVA other harmonic loads, including a 2MVA 6-pulse DC drive
- ⇒ total harmonic load is then 4.9MVA (=1.00x3.2+0.85x2.0), as per Eq. (2.1)
- ⇒ Therefore percentage total harmonic load is 16.3% (=4.9/30)
- ⇒ As per Figure B.1, point (57, 16.3%) falls below the 69kV curve. The installation passes harmonic chart requirement. Harmonic resonance check is followed.

- The plant capacitor banks, installed in one location, are 2.1 MVar
 - The fault level at the capacitor bus is 190MVA
- ⇒ Therefore $h_{\text{resonance}}$ is 9.51 (=SQRT(190/2.1))

$$| h_{\text{resonance}} - h | = 0.51 > 0.15 \text{ for } h=9 \quad \Rightarrow \text{okay}$$
$$= 0.49 > 0.10 \text{ for } h=10 \Rightarrow \text{okay}$$

Conclusion: The installation meets the requirements of harmonic chart as well as harmonic resonance check. The installation is a category I type.

3. HARMONIC LIMITS FOR DESIGN PURPOSES

3.1 General

At the plant design stage, category II customers shall satisfy BC Hydro that the calculated current and voltage distortions at the point of interconnection shall not exceed the design limits. Worst case normal operating conditions shall be used in the calculation of harmonic distortions. For customers with transformer arrangements that result in zero sequence current injections into the Facilities, the amount of zero sequence harmonic current injections must be calculated. For those customers whose loads are unbalanced among three phases and can result in a voltage unbalance² greater than 1.5% at POI, three-phase harmonic analysis is required.

3.2 Harmonic Current Limits

Limits for harmonic current distortion are shown in Tables 3.1A, 3.1B and 3.1C. These limits apply to each phase current individually at the point of interconnection. Harmonic current distortion shall be calculated using two sets of system impedance data:

- (a) The supply system harmonic impedance as seen from the point of interconnection is zero at all harmonic frequencies. This assumption is needed since the system harmonic impedance can be zero at any frequency due to resonances in the Facilities. Using zero harmonic impedance also ensures that the customer plants contain their own harmonic currents and the harmonic currents escaping into the Facilities are minimized.
- (b) The supply system harmonic impedances are the same as those provided by BC Hydro. The purpose is to determine if there is any excessive harmonic current injection into the Facilities caused by the harmonic resonance between the system impedance and the customer capacitor banks.

It must be noted that the limits shown in Tables 3.1A, 3.1B, and 3.1C apply only to the harmonic currents introduced by customer installations. A zero background harmonic distortion shall be assumed in the calculation therefore. The results are the harmonic currents exclusively due to customer installations. Since problems may be caused by the amount of harmonic current injections into supply systems irrespective to the magnitude of fundamental frequency current at the POI, this guide also imposes ampere limits on the total harmonic current injection. For most Load customers, satisfying the percentage harmonic current limits generally results in the satisfaction of the ampere limits.

² Voltage unbalance is defined as the ratio of negative sequence voltage to the positive sequence voltage.

Table 3.1 A: Harmonic Current Distortion Limits (69 kV)

I_{sc} / I_L	$h < 11$	$11 \leq h < 17$	$17 \leq h < 23$	$23 \leq h < 35$	$35 \leq h$	THD
≤ 20	4.0	2.0	1.5	0.6	0.3	5.0
(20 50)	7.0	3.5	2.5	1.0	0.5	8.0
(50 100)	10.0	4.5	4.0	1.5	0.7	12.0
(100 1000)	12.0	5.5	5.0	2.0	1.0	15.0
> 1000	15.0	7.0	6.0	2.5	1.4	20.0
Limits for total harmonic current: 20 A						
Note:	1. Even harmonics are limited to 25% of the IHD limits above. 2. Triple order harmonics are limited to 35% of the IHD limits above.					
Where	I_{sc} = Maximum system short circuit current at POI. I_L = Maximum fundamental frequency total load current at POI. h = Harmonic order.					

Table 3.1 B: Harmonic Current Distortion Limits (138 kV)

I_{sc} / I_L	$h < 11$	$11 \leq h < 17$	$17 \leq h < 23$	$23 \leq h < 35$	$35 \leq h$	THD
≤ 20	2.0	1.0	0.75	0.3	0.15	2.5
(20 50]	3.5	1.75	1.25	0.5	0.25	4.0
(50 100]	5.0	2.25	2.0	0.75	0.35	6.0
(100 1000]	6.0	2.75	2.5	1.0	0.5	7.5
> 1000	7.5	3.5	3.0	1.25	0.7	10.0
Limits for total harmonic current: 10 A						
Note:	1. Even harmonics are limited to 25% of the IHD limits above. 2. Triple order harmonics are limited to 35% of the IHD limits above.					
Where	I_{sc} = Maximum system short circuit current at POI. I_L = Maximum fundamental frequency total load current at POI. h = Harmonic order.					

Table 3.1 C: Harmonic Current Distortion Limits (above 138 kV)

I_{sc} / I_L	$h < 11$	$11 \leq h < 17$	$17 \leq h < 23$	$23 \leq h < 35$	$35 \leq h$	THD
<50	2.0	1.0	0.75	0.3	0.15	2.5
≥ 50	3.0	1.5	1.15	0.45	0.22	3.75
Limits for total harmonic current: 6 A						
Note: 1. Even harmonics are limited to 25% of the IHD limits above. 2. Triple order harmonics are limited to 35% of the IHD limits above.						
Where I_{sc} = Maximum system short circuit current at POI. I_L = Maximum fundamental frequency total load current at POI. h = Harmonic order.						

3.3 Harmonic Voltage Limits

Limits for harmonic voltage distortion at the point of interconnection are listed in Table 3.2. Reducing harmonic voltage distortion is the responsibility shared between BC Hydro and the customers. A first-come-first-served policy is adopted in this guide. While BC Hydro is responsible to maintain the voltage distortion within the limits of Table 3.2, a new customer installation is limited to add certain harmonic voltage distortion at the POI such that the combined voltage harmonics of background and customer contribution is within the limits of Table 3.2. Thus, the following two (2) conditions shall be met:

$$1) \sum_{h=2}^{40} \frac{V_h}{h} + \sum_{h=2}^{40} \frac{V_{h,c}}{h} \leq \sum_{h=2}^{40} \frac{V_{h,l}}{h}$$

$$2) \sqrt{\sum_{h=2}^{40} \left(\frac{V_h}{h} + \frac{V_{h,c}}{h} \right)^2} \leq \sum_{h=2}^{40} \frac{V_{h,l}}{h} \quad (3.1)$$

$$\sum_{h=2}^{40} \frac{V_{h,c}}{h}^2$$

The harmonic voltage limits apply to each phase voltage individually at the point of interconnection. The supply system harmonic impedance data provided by BC Hydro shall be used to determine the harmonic voltage distortions caused by the customer plants.

Table 3.2: Harmonic Voltage Distortion Limits

POI Voltage	Voltage IHD (%)	Voltage THD (%)
69 kV	3.0	5.0
138 kV	1.5	2.5
230 kV and above	1.0	1.5

3.4 Engineering Information Provided by BC Hydro

BC Hydro will provide, the necessary engineering information for customer harmonic analysis. If the information is considered to be critical to the equipment design, any customer can require BC Hydro to supply more accurate technical data, at customer's expense, based on dedicated field measurements or harmonic studies on Facilities. The engineering information provided by BC Hydro includes:

- (a) System fault level for harmonic studies: It is the fault level calculated for the normal system operating conditions. The fault level may not be the same as those used to determine the breaker rating and protection setting of the customer plant. BC Hydro will specify what fault levels shall be used for harmonic analysis.
- (b) Supply system harmonic impedance: This information may be determined from field measurements and/or computer simulations by BC Hydro. It shall include various operating conditions, network configurations and future system expansions. Depending on the location and size of the plant, the harmonic impedance may take different forms:
 - (i) Impedances calculated from several system fault levels.
 - (ii) A curve of system impedance as a function of frequency.
 - (iii) A family of impedance-frequency curves.
 - (iv) A range of harmonic impedances at each harmonic frequency.
- (c) Background harmonic voltage distortion: This information will be supplied in the form of harmonic voltage spectrums (magnitude). The data may be estimated according to BC Hydro's power quality survey data bank, measured at the point of interconnection, or calculated from harmonic analysis.
- (d) Supply voltage unbalance: BC Hydro is responsible to supply a voltage at the point of interconnection with at most 1.5% voltage unbalance. A voltage unbalance is defined as the ratio of negative sequence voltage with respect to the positive sequence voltage. Since the generation of harmonic currents is very sensitive to the supply voltage unbalance, the effects of voltage unbalance must be considered in customer's harmonic studies. For those customers with balanced three-phase loads, this means that the harmonic current spectrums representing the harmonic-producing loads must be determined assuming that there exists a 2% unbalance at the supply voltage. Under such a condition, a twelve-pulse DC drive is expected to produce 5th and 7th harmonic currents. As long as the harmonic source spectrums are modified to take into account the unbalance effects, harmonic analysis with a single-phase network representation is acceptable. For those customer plants with unbalanced three-phase loads (see Section 3.1 for the criteria), three-phase harmonic analysis is required. A voltage unbalance of 1.5% at the POI shall be used in the study.

3.5 Other Considerations

- (a) Telephone interference due to harmonics

This guideline imposes no specific design limits on the calculated I*T values. This is because that the telephone interference is, in the majority of cases, caused by residual (zero sequence)

harmonic currents. For those customers whose supply transformers are connected with primary in delta or ungrounded-star form, the calculated residual current flowing into the Facilities is always zero, and therefore, no direct telephone interference is expected. It shall be noted, however, that indirect harmonic-telephone interference is still possible. These interferences may be caused by the interaction of non-residual harmonic currents with the equipment of the supply system. Since the indirect interference is impossible to predict in most cases, the philosophy adopted in this guideline is to limit the total harmonic current in ampere value and the triple order harmonic current distortion, in addition to the IEEE limitations on IHD and THD.

For those customers supplied by transformers with grounded-star primary, three-phase harmonic and telephone interference studies are recommended. These studies can reduce the likelihood of the installation violating BC Hydro's telephone interference measurement limits specified in Section 4. As an approximate guide, the limit on calculated residual I*T product can be determined according to Equation (3.2). More accurate methods to assess the interference are described in reference 1.3(f) above.

$$\text{Maximum Residual } I^*T \text{ (A)} < \frac{1450 \text{ (A*km)}}{\text{Length of parallel exposure (km)}} \quad (3.2)$$

- (b) Effects of background harmonics on customer capacitors

While trying to meet BC Hydro's harmonic limits at the point of interconnection, customers may also keep in mind that their capacitors may become a sink for the harmonic currents outside their plants. This problem is normally caused by the parallel resonance between the capacitors and the system impedance (including the supply transformer impedance). Adherence to Equation (2.2) of Section 2.1 may reduce the likelihood of resonance and capacitor overload. But detailed harmonic and capacitor sizing studies are recommended.

4. HARMONIC LIMITS FOR MEASUREMENT PURPOSES

4.1 General

BC Hydro can perform or request the Customer to perform harmonic measurement tests. Harmonic tests and limit checks shall be conducted during the normal plant operating cycles. Conditions that require harmonic measurements may include:

- (a) Harmonic problems are reported;
- (b) New customer plant is commissioned; or
- (c) Major system changes, either in the Facilities or in customer plant, are implemented.

4.2 Limits on Current and Voltage Distortions

The limits for measured harmonics are based on the design harmonic limits. However, factors such as time-varying nature of harmonics and customer plant startup conditions are taken into account. In other words, short time bursts of harmonic distortions higher than the design limits are generally acceptable. Two indices shall be used to measure the degree of harmonic bursts:

- (a) Maximum Duration of Harmonic Burst (T_{maximum}): This is the maximum time interval in which the harmonic distortion exceeds a particular IHD or THD level during a 24 hour measurement period.
- (b) Total Duration of Harmonic Burst (T_{total}): This is the summation of all the time intervals in which the harmonic distortion exceeds a particular IHD or THD level during a 24 hour measurement period.

The 24 hour measurement period shall be established on a calendar day basis. BC Hydro requires that, for 95% of the measurements (namely, 95 days out of 100 days), the measured IHD and THD levels must be limited according to the maximum and the total durations of harmonic burst T_{maximum} and T_{total} , as shown in Table 4.1 and Figure 4.1.

4.3 Limits on Telephone Interference

Telephone interference due to harmonics is a complex problem that involves three major factors: the existence of source of influence, the coupling between the source and telephone cable, and the susceptibility of telephone equipment. I*T product only addresses the problem of source of influence and therefore is incomplete. On the other hand, the complexity of the problem makes it impossible to accurately calculate the interference level with all three factors included. As a result, this guideline relies on measurements to check compliance.

The telephone interference measurement will be performed on any telephone set vulnerable to the customer plant harmonics. Two values, the noise to ground (N_g) and the noise metallic (N_m) will be measured. BC Hydro requires that, subject to cable balance ($N_g - N_m$) greater than 60.0 dBmC, the noise to ground level shall be lower than 80.0 dBmC.

4.4 Instrumentation Requirements

Instruments, which may include PT's and CT's, used for harmonic distortion and telephone interference measurements must be certified by BC Hydro. If there is any dispute over the accuracy of an instrument, CSA standard C22.2 (see references 1.3(b) and 1.3(c) above) shall be used to resolve the dispute.

Table 4.1: Limits for Measured Harmonic Distortions

Maximum Duration of Harmonic Burst (T_{maximum})	Acceptable harmonic distortion level THD and IHD
1 sec < T_{maximum} ≤ 5 sec	3.0x (design limits)
5 sec < T_{maximum} ≤ 10 mins	2.0x (design limits)
10 min < T_{maximum} ≤ 30 mins	1.5x (design limits)
30 min < T_{maximum}	1.0x (design limits)
Total Duration of Harmonic Burst (T_{total})	Acceptable harmonic distortion level THD and IHD
15 sec < T_{total} ≤ 60 sec.	3.0x (design limits)
60 sec < T_{total} ≤ 40 min.	2.0x (design limits)
40 min < T_{total} ≤ 120min.	1.5x (design limits)
120 min < T_{total}	1.0x (design limits)

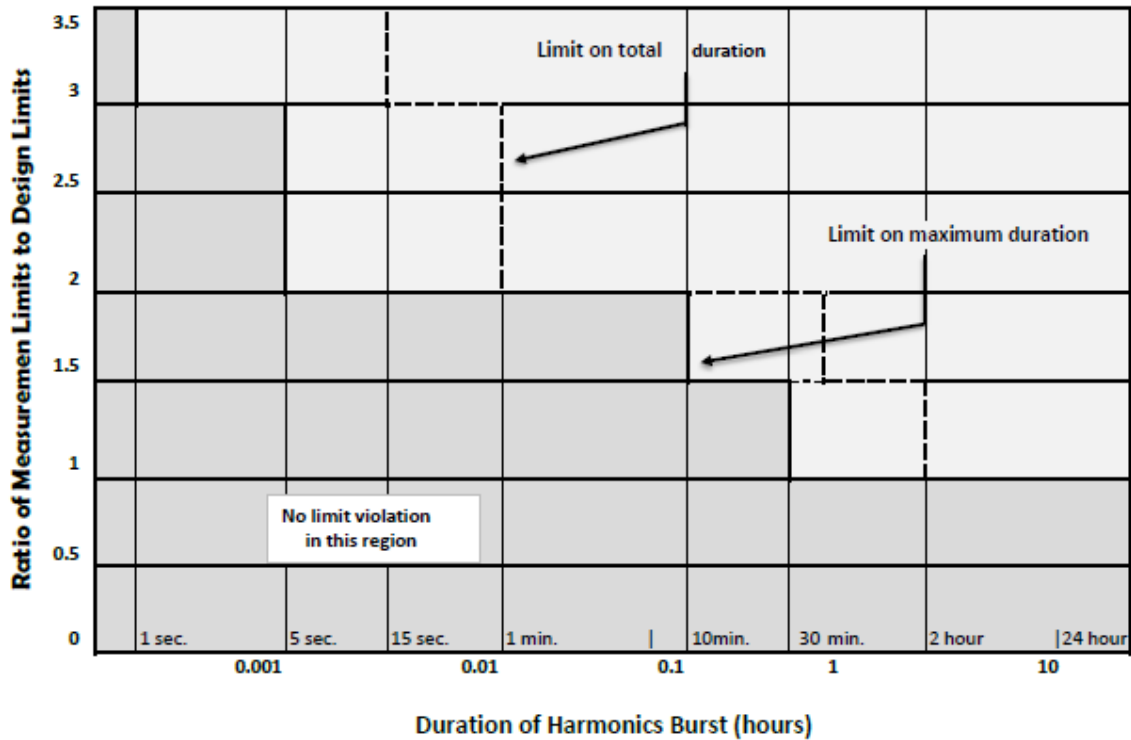

Figure 4.1: BC Hydro's Limits on measured harmonics

5. RESPONSIBILITIES FOR MITIGATION OF HARMONIC PROBLEMS

Adherence to the recommended limits of this guideline should reduce the risks of damage to, or malfunctioning of, other customer's or the Transmission provider's equipment. This section defines the responsibilities of each involved party to mitigate harmonic problems as described in section 19, Endangerment, Interference, of the Electricity Supply Agreement.

5.1 Harmonic Limits Exceeded

BC Hydro is responsible to ensure that the background harmonic voltage distortion at the point of interconnection is within the voltage distortion limits jointly specified in Table 3.1A, 3.1B, 3.1C and Table 4.1.

The customer is responsible to ensure that its portion of harmonic current distortion at the point of interconnection is always within BC Hydro's harmonic current distortion limits.

The customer is responsible to reduce the harmonic voltage distortion at the point of interconnection to BC Hydro's voltage distortion limits. However, if the actual supply system harmonic impedances and background voltage distortions are outside the ranges determined by BC Hydro, B.C. Hydro is responsible to reduce the harmonic voltage distortion.

Telephone interference limits shall be complied with only if there is a harmonic-caused telephone interference problem. Subject to (1) noise to ground level greater than 80.0 dBmC and telephone cable balance greater than 60.0 dBmC or (2) noise to ground level greater than 90.0 dBmC, the customer is responsible to mitigate the telephone interference problem. However, if the actual supply system harmonic impedances are outside the range determined by BC Hydro, BC Hydro is responsible to mitigate the problem.

5.2 Harmonic Limits not Exceeded

Problems caused by harmonics may arise even if harmonic limits are not violated. Under these circumstances, all involved parties may be responsible to mitigate the problems.

5.3 Determination of Limit Violation

BC Hydro is responsible to demonstrate the violation of harmonic voltage and current limits and identify the customer that causes harmonic problem. The telephone companies, with BC Hydro's cooperation, are responsible to demonstrate the violation of telephone interference limits and identify the customer that causes the interference problem.

APPENDIX E
BC HYDRO VOLTAGE FLICKER PRACTICES

1. INTRODUCTION

Voltage fluctuations occurring more frequently than once per hour will be referred to as voltage flicker. Voltage flicker can result in light flicker that can at various frequencies and magnitudes become irritating to the human eye. Experimentation shows that light flicker is visible at voltage fluctuations as low as 0.2% if the frequency of occurrence is in the 5 fluctuations per second range and become irritating at magnitude 0.5% for the same frequency. At a frequency of 1 fluctuation per minute light flicker becomes irritating at a magnitude of 2%. See Figure 1

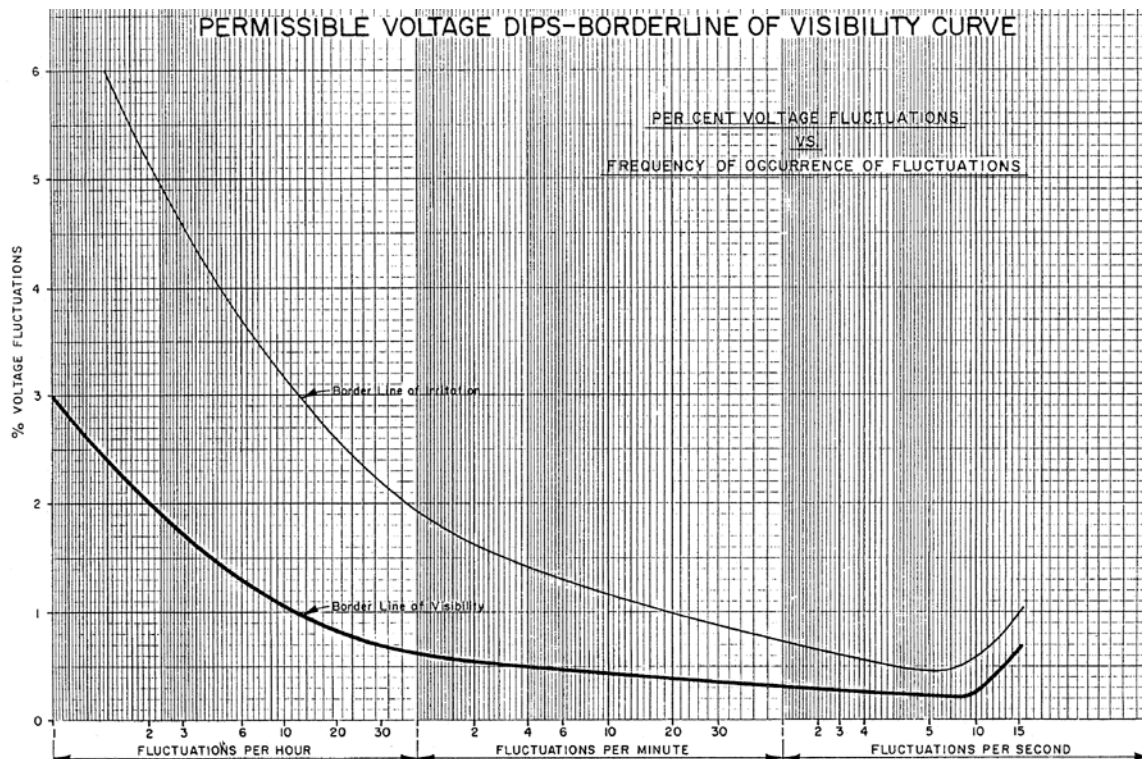

Figure 1: Permissible Voltage Dips-Borderline of Visibility Curve

BC Hydro aims to control the overall flicker levels to within acceptable levels by placing limits on voltage fluctuations introduced at the Point of Interconnection. Based on the Customer’s proposed Point of Interconnection and associated minimum source strength provided by BC Hydro under normal system operation condition, the customer’s responsibility is to ensure the design and operation of their facility does not introduce voltage fluctuations beyond the specified limits in this document.

Depending on the type of Customer’s Facilities load, voltage flicker can be either periodic (Chipper) or random (arc furnace) in nature. Voltage fluctuations occurring less frequent than once per hour are managed according to limits established in this appendix. These voltage fluctuations are typically deterministic in nature (knowledge of occurrence is known).

Voltage Flicker is measured according to the standard IEC 61000-4-15 (active). Measurement parameters for voltage flicker are:

Pst^1 – Short term flicker indicator which is the flicker severity measured over a short period (10 minutes). $Pst = 1$ is the conventional threshold of irritation

Plt^2 – Long term flicker indicator which is the flicker severity measured over a long period (2 hours) using successive Pst values.

2. BC HYDRO VOLTAGE FLICKER TARGETS

Voltage flicker is typically not produced by electric system utilities. BC Hydro attempts to manage voltage flicker to avoid customer complaints. BC Hydro target values for voltage flicker on the BC Hydro system are:

$Pst < 1.0$ 99% of the time

$Plt < 0.8$ 99% of the time

3. CUSTOMER'S FACILITIES VOLTAGE FLICKER REQUIREMENTS

Customer flicker design requirements – The Customer shall plan, design and construct the Customer's Facilities based on BC Hydro provided normal system fault levels to meet the following voltage flicker requirements as determined at the POI:

$Pst < 0.8$ for more than 95% of the time

$Plt < 0.6$ for more than 95% of the time

In operation the Customer's Facilities shall meet the following voltage flicker requirements:

$Pst < 1.0$ for more than 99% of the time

$Plt < 0.8$ for more than 99% of the time

4. VOLTAGE FLICKER ASSESSMENT PROCESS

BC Hydro recognizes that majority of Customer loads have a low risk of creating voltage flicker outside the established limits. Thus, only those Customers with high risk of voltage fluctuations leading to flicker conditions are required to perform a detail assessment during the design phase. The general process flow to meet BC Hydro flicker requirements is outlined in Fig.2

¹ Definition from IEC 61000 3-3.

² *Ibid.*

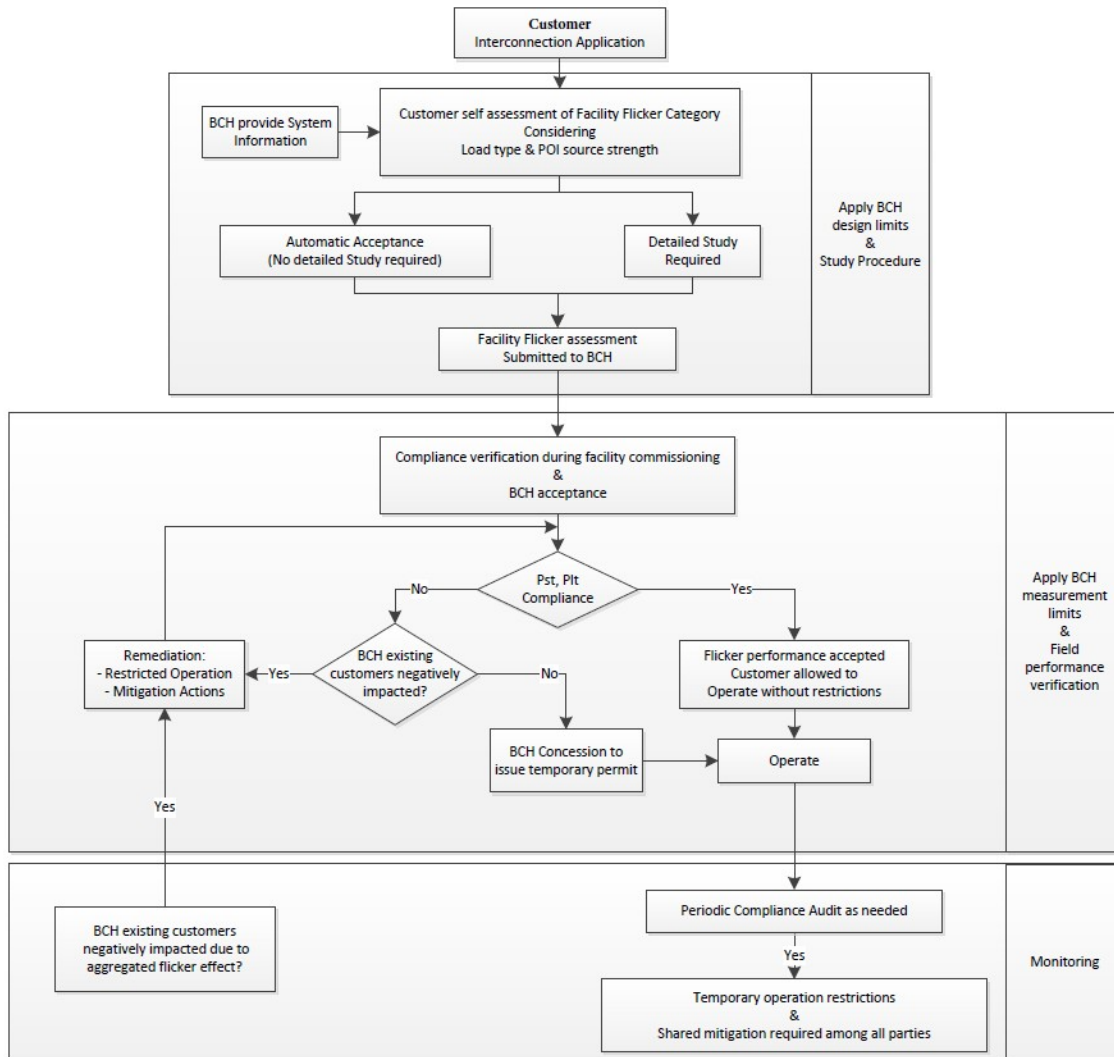

Fig.2 – General process flow to meet BC Hydro flicker requirements

4.1 Automatic Acceptance

If the rate of voltage flicker is known, the voltage flicker magnitude of a new Customer load can be related to the maximum apparent power (S_{max}) of the load to the minimum short circuit power (S_{sc}) under normal system condition at the POI as follows:

$$\text{Voltage flicker magnitude} = \frac{\Delta VV \%}{VV} = \frac{SSSSrrrS}{SSrrr} \cdot 100$$

- S_{max} should include the maximum power seen during starting:
 - o For induction motors, S_{max} is typically 6 to 8 times the rated power
 - o For induction furnaces, S_{max} is typically 2 to 4 times the rated power
- S_{sc} is the minimum short circuit strength at the POI under normal system operation

Accordingly, for cases where the rate is less than once per hour the limits for voltage fluctuations should be limited using the following table:

Voltage Flicker Rate Changes per minute	$\Delta V/V$ % $(S_{max}/S_{sc}) * 100$
< 10	0.4 %
10 to 2100	0.2 %
> 200	0.1 %

Table 1 – Limits for relative power variations, taken from IEC 61000-3-7 Table 3

Loads having $\Delta V/V$ % values at or below the levels specified in Table 1 are considered acceptable and further flicker analysis and monitoring is not required. For values above the limits, Customer shall discuss with BC Hydro regarding further flicker analysis and monitoring requirements.

4.2 Detailed Flicker Assessment

For facilities that have fluctuating loads without clear variation patterns such as arc-furnace and chipping mills, the IEC flicker measurement standard is adopted by BC Hydro. The Customer is required to conduct a voltage flicker assessment at the facility design stage following BC Hydro design limits and submit the proposed facility performance including mitigation solutions to BC Hydro for review. Adherence to the recommended limits of this guide should minimize the risk of flicker problems for other BC Hydro customers. In addition, Customer is required to demonstrate its facility meets the measurement limits when the facility is put into operation. BC Hydro reserves the right to request Customer to, at Customer's cost, implement continuous monitoring of Pst and Plt if considered necessary and/or when flicker complaints are received from other customers.

5. VOLTAGE FLICKER MEASUREMENT

Voltage flicker levels shall:

- (a) Measure the overall flicker level (Pst and Plt) over a representative load cycle of 1 day or greater.
- (b) Be measured using a power quality device that meets the requirements of the IEC Flickermeter standard 61000-4-15. The data from a flicker meter shall be evaluated using a cumulative frequency method.
- (c) Be measured at the Point of Interconnection.

Note: BC Hydro preferred data exchange format is IEEE comtrade

5.2 Non-compliant Measurement

Where voltage flicker measurements exceed the limits at the Point of Interconnection the customer is responsible to reduce its flicker disturbance emission so that the voltage flicker level contributed by the

customer does not exceed limits. However, if a facility has met the flicker limit as verified at the facility commissioning test and the supply system fault level has changed since then, BC Hydro is responsible to mitigate the voltage flicker problem.

5.3 Compliant Measurement

Where Customer’s Facilities are compliant with the limits set, problems caused by voltage flicker may still arise. BC Hydro will at its discretion monitor voltage flicker performance on the system. Where customer complaints are being investigated BC Hydro will determine the violation of flicker limits and identify customers that cause the flicker problems.

6. RESPONSIBILITIES FOR DISTURBANCE MITIGATION

Adherence to the recommended limits of this guideline should reduce the risks of damage to, or malfunctioning of other customer’s or BC Hydro’s equipment and risks of complaints by other BC Hydro customers. If problems occur, all involved parties may be responsible to mitigate the problems.

7. FLICKER CURVE FOR PERIODIC VOLTAGE FLUCTUATIONS

When voltage fluctuations have repetitive pattern with known frequencies, they may be called “periodic fluctuations” where typically frequency of occurrence is greater than one change per minute. Industrial plants such as arc furnaces, welders, motor logging and saw mills will produce such repetitive voltage fluctuations.

For facilities with approximately known fluctuation pattern, i.e. the magnitude of fluctuation and frequency of fluctuation, the following curve may be used. This curve is derived from the IEC flicker meter standards and is consistent with the flicker meter limits. The purpose of recommending this curve is that some of the limit verification studies can be simplified without resorting to the flicker meter standards. BC Hydro requires that individual loads do not introduce voltage fluctuations, at their POI, above the curves shown in the Figure 3 below.

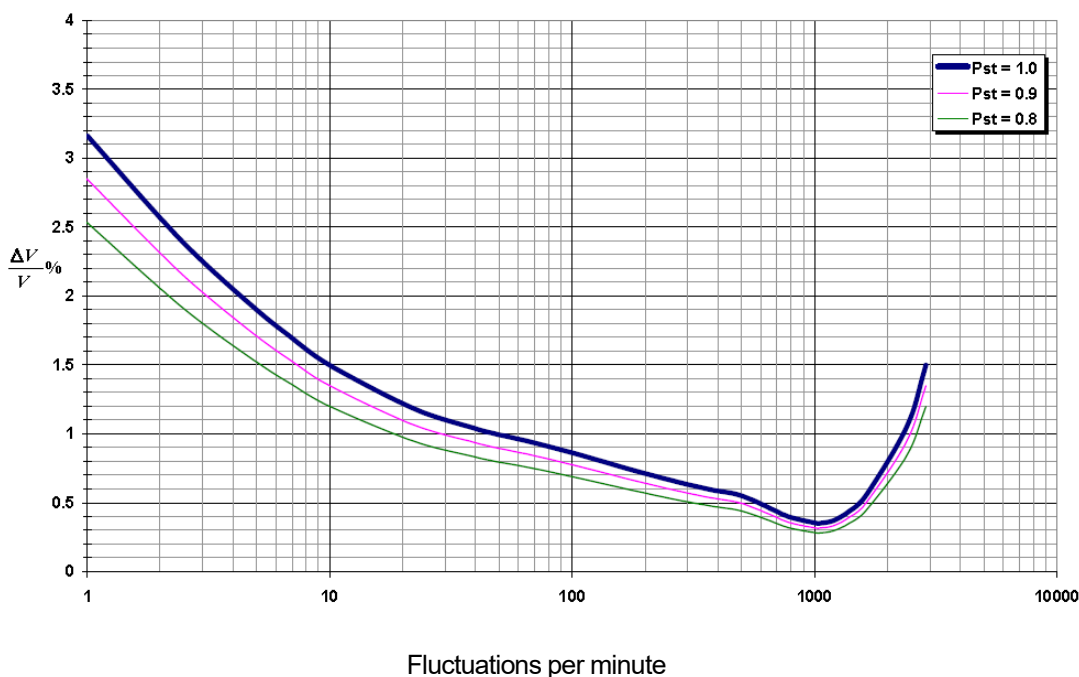

Figure 3 – IEC 61000-3-7 Flicker Curve For Periodic Voltage Fluctuations.

Notes:

- (a) The values were obtained experimentally through rectangular modulation of the 60 Hz AC waveform.
- (b) The human eye is most sensitive to fluctuations occurring at 8Hz, or 16 voltage changes per second. To convert the horizontal scale to fluctuations/sec. (Hz), divide by 120.
- (c) To meet BC Hydro limits, the $\Delta V/V$ % must fall on or below the corresponding PST curve, at the projected fluctuation rate. For loads with varying fluctuation rates (e.g. arc furnace) $\Delta V/V$ % should be checked against a representative range of fluctuation rates.

8. CUMULATIVE FREQUENCY ANALYSIS

The flicker data collected during a representative benchmark measurement is sometimes difficult to analyze (see Figure 4 below). As a result, it is best analyzed by plotting the PST values in a cumulative frequency graph. From this graph, the number of PST values above or below a particular threshold can be determined (see Figure 5 below).

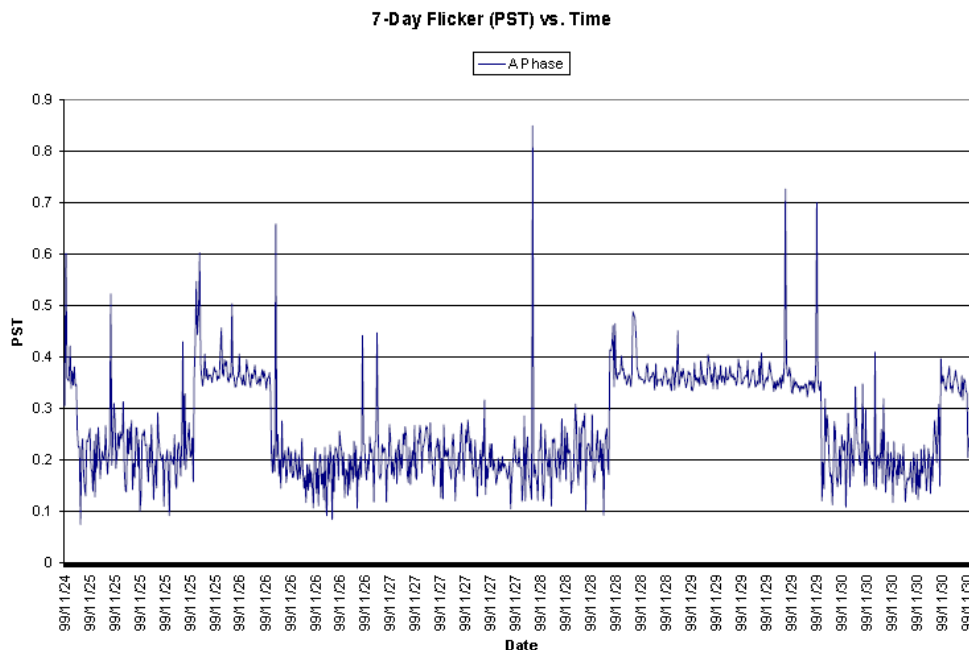

Figure 4 – Voltage Flicker (Pst) vs time

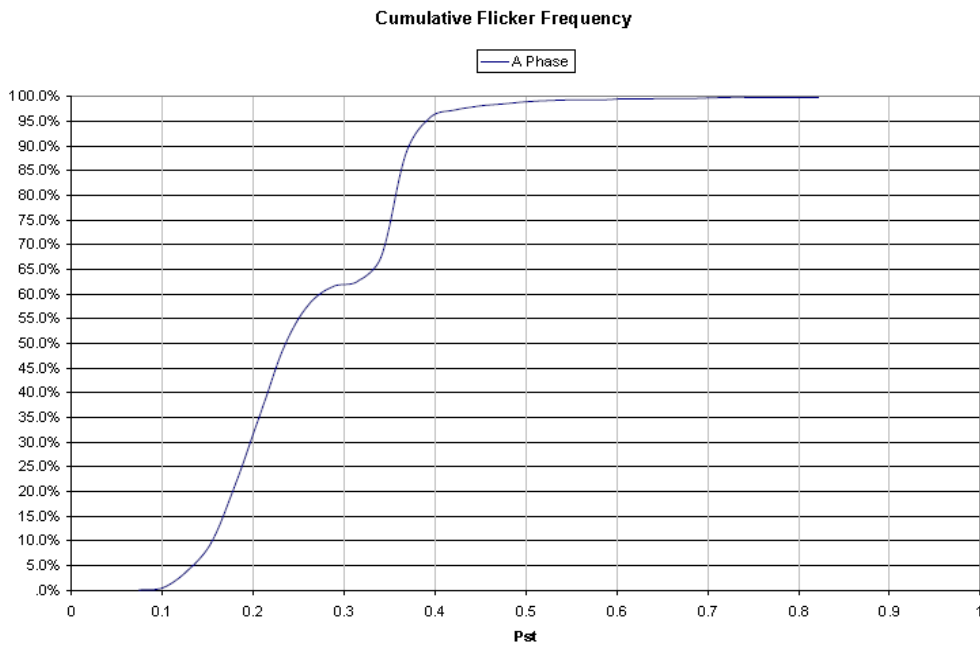

Figure 5- Voltage Flicker Accumulative flicker frequency

**APPENDIX F
CUSTOMER SCADA DESIGN PROCEDURE**

The following is an extract from BC Hydro Engineering Standard ES45-P0210.

According to BC Hydro Design Practice DP 45-P0200, the Customer is recommended to use a GE IBOX RTU as a minimum for the interface equipment between the Customer and the BC Hydro supervisory control and data acquisition (SCADA) network. This will de-couple the design and testing of the Customer equipment from the BC Hydro Control Centre and allow the Control Centre to prepare and pre-commission a new RTU database with a test IBOX setup by the BC Hydro SCADA designer.

The Customer SCADA designer shall follow Step 3b but with additional telecommunication options including dial-up, satellite and cellular data. At the beginning of the project cycle, the Customer SCADA designer shall determine the technical details of the IBOX in discussion with the BC Hydro SCADA designer. The Customer SCADA designer shall submit technical information and IBOX configuration to enable the BC Hydro SCADA designer to complete the design at the Data Concentration Point and pre-commission with BC Hydro Control Centre.

If the Customer belongs to one of the BC Hydro pre-defined Customer types with a standardized DNP point list, a sample IBOX Configuration can be requested from the BC Hydro SCADA team for the Customer's reference. After the project is in service, the BC Hydro SCADA designer will archive the RTU configuration according to BC Hydro Engineering Standards.

Step 3b. External consultant or Customer adding a new GE RTU

At the beginning of the project cycle—with a minimum of three months before the in service date—send the P&C scope document to the BC Hydro SCADA designer and request the following information needed to set up a new RTU in the BC Hydro system:

- DNP address
- IP address
- Data Concentration Point
- GE firmware version
- GE BOOTROM version
- GE Config Pro version

The network address assignment shall be made according to Design Practice DP 45-Q0022. The external consultant shall also request all the RTU drawing numbers from BC Hydro except for the R27 drawing number which will be reserved by the BC Hydro SCADA designer during archiving of the RTU configuration.

The external consultant shall submit to the BC Hydro SCADA designer the station LAN design architecture for review during the conceptual design phase of the project. The external consultant shall consult with the BC Hydro Telecommunications Department to ascertain whether direct RS232 connection or leased line dedicated modem connection will be used for the station involved. Based on that result, the external consultant shall request the BC Hydro SCADA designer to reserve either a direct connect RS232 port or a four wire modem port at the Data Concentration Point.

The external consultant shall prepare a tested version of the RTU Configuration and send to the BC Hydro SCADA designer—together with all RTU drawings, P&C drawings and DNP point lists of all LAN devices—at least ten weeks before the in service date. The BC Hydro SCADA designer will perform pre-commissioning with BC Hydro Control Centre and archive the RTU configuration according to BC

Hydro Engineering Standards after the project is in service. The external consultant is responsible for all hardware design, RTU drawings, installation, testing and commissioning.

APPENDIX G
REMEDIAL ACTION SCHEME REQUIREMENTS**1. Introduction**

BC Hydro may require that the Transmission Voltage Customer (TVC) participate in a BC Hydro Remedial Action Scheme (RAS) as a prerequisite for interconnection. Typically, this involves participating in a BC Hydro load shedding scheme. BC Hydro will provide the requirements of the RAS system. The RAS system will include BC Hydro owned, operated and maintained RAS facilities and TVC owned, operated and maintained RAS facilities. The TVC will design, install, commission and maintain the TVC facilities of the RAS system. BC Hydro will take on the role of “Reporting Party” and present the RAS design to the WECC Remedial Action Scheme Reliability Subcommittee (RASRS). While BC Hydro will present the RAS design on behalf of the TVC, the TVC is responsible for the design and all corrective measures resulting from the review. The time associated with the RASRS approval process needs to be considered by the TVC.

2. Mandatory Reliability Standards:

By participating in a RAS, the TVC will be subject to requirements under active Mandatory Reliability Standards (MRS) PRC-015-1 (Remedial Action Scheme Data and Documentation), PRC-016-1 (Remedial Action Scheme Misoperations) and PRC-017-1 (Remedial Action Scheme Maintenance and Testing)⁵. As the Reporting Party, BC Hydro will present the RAS to the RASRS for review, but it is the TVC’s responsibility to retain evidence to demonstrate MRS compliance. The TVC will cooperate with BC Hydro staff reviewing and analyzing RAS operations and scheduling and testing RAS systems.

3. Design:

RAS systems must be designed such that *a single RAS component failure, when the RAS was intended to operate, does not prevent the interconnected transmission system from meeting the performance requirements defined in MRS planning standards TPL (active)*. Unless otherwise stated by BC Hydro, this implies a fully redundant design, where the two RAS systems have no common points of failure. Station batteries are not required to be redundant, but the redundant ‘A’ and ‘B’ RAS systems cannot share common DC circuits. Where dual trip coils are provided, they must both be used. In addition, to prevent failure of the breaker mechanism from meeting the performance requirements, either breaker failure protection must be applied, or two series breakers must be tripped. If breaker failure protection is applied, the pickup of the overcurrent supervision element must be set low enough for the breaker failure protection to operate during non-fault (ie: RAS) conditions. Frequency diversity microwave is considered to be redundant, but optic fibres must maintain a minimum 3m separation between ‘A’ and ‘B’ fibres to be considered redundant. GPS time tagged recording of RAS initiation and actions must be provided to allow post-event analysis and verification that the RAS meets the defined performance requirements. BC Hydro’s RAS systems are typically required to operate in timeframes as short as 9 cycles from fault initiation to completion of remedial action (interruption of current in a circuit breaker). In order to achieve this high speed action, it is important that superfluous equipment is not inserted into the RAS. Typical shedding schemes have teleprotection picking up a high speed auxiliary relay which directly trips the circuit breaker, initiates breaker failure protection and keys local time tagging equipment. Routing of tripping signals through protective relays is discouraged. Routing of tripping signals through control systems is unacceptable.

⁵ (footnote # seems strange, why 6? Do not see #4 and #5, is this correct footnote format?) The requirements in these standards may be superseded by those in PRC-012-2 (Remedial Action Schemes) after 2020.

4. Performance Verification:

In addition to normal testing of protection and control systems, BC Hydro will require end to end testing of the RAS system into the TVC's plant before it is put into service in order to verify that the RAS meets its performance requirements.

5. Outage Scheduling:

RAS systems are often distributed schemes which span large geographical areas. In these systems, two seemingly uncorrelated equipment outages may result in a loss of RAS functionality. In order to ensure that the RAS is fully available, all outages of RAS equipment must be coordinated through BC Hydro's control center. In addition, all RAS equipment must be monitored and failures of RAS equipment must be reported to BC Hydro's control centre.

References:

1. WECC RAS Design Guide
<https://www.wecc.biz/Reliability/RWG%20RAS%20Design%20Guide%20%20Final.pdf>
2. WECC Procedure and Information Required for RAS Assessment
<https://www.wecc.biz/Administrative/10a%20Procedure%20and%20Information%20Required%20for%20RAS%20Assessment.pdf>
3. RAS Definition
https://extranet.bchydro.com/sites/rc_bcuc/BC%20Approved%20Standards%20Library/ Glossary_of_Terms%202016-11-28.pdf
4. NERC standard PRC-015-1 Remedial Action Scheme Data and Documentation
5. NERC standard PRC-016-1 Remedial Action Scheme Misoperations
6. NERC standard PRC-017-1 Remedial Action Scheme Maintenance and Testing